

The United States Lighthouse Society
Review Of
Lighthouse Related Patent Models
In The
Smithsonian Institution
National American History Museum

By

Thomas A. Tag
Technical Advisor
US Lighthouse Society

Copyright © 2012 by Thomas A. Tag

All rights reserved. No part of this book may be reproduced or transmitted in any form or by any means, electronic or mechanical, including photocopying or recording, or used in any information storage or retrieval system, without permission in writing from the Author.

Printed in the United States of America

Thomas A. Tag
6621 N. Northwest Hwy.
Chicago, IL 60631

Introduction

The United States Lighthouse Society became aware that some lighthouse related patent models existed within the National American History Museum in early 2011. We decided to produce a document identifying and defining these models and set plans in motion for the project in early 2012. This document is the result of that effort. It was produced with the help of a number of curators working at the Smithsonian National American History Museum (NAHM). Involved were: Fath Davis Ruffins, Barbara Janssen, Bill Yeingst, and Jennifer Strobel. We wish to thank them for their assistance in obtaining photographs of the various patent models. Chad Kaiser was also involved in the project and supplied the photograph of Wigham's Gas Burner, which is in a private collection.

What are Patent Models?

A Patent Model is a prototype of the invention, which law once required an inventor to submit to the U.S. Patent Office, in Washington, when seeking a patent. According to the Patent Act of July 4, 1836: "The model, not more than 12 inches square, should be neatly made, and the name of the inventor should be printed or engraved upon, or affixed to it, in a durable manner." Patent models were all miniature devices, which greatly added to their appeal. Patent Models were sent to the US Patent Office with the patent drawings and specifications, which outlined the inventor's claims as to why his idea was new. The Patent Office examiners then used the models, along with the drawings and claims, to help them to understand the invention and how it worked. The inventor would often hire a professional model maker to turn his two-dimensional drawings into a three-dimensional miniature of his invention. Some inventors constructed their own models, but most used outside craftsman. The inventor had a choice of modeling the complete invention or only the patented element. Most inventors took great care to ensure their models were neither too small to be seen on the cabinet shelves in the Patent Office Model Museum nor too large to fit there.

When a model arrived at the Patent Office, a receiving tag was made and attached to the model. Many of those tags survived and remain with the models today. After the review process was completed and if a patent was to be issued, a formal patent tag was created. It displayed the patent number, reissues of the patent – if any, patent date, inventor's name and the name of the invention. This official patent tag was affixed to the model with a piece of thin, red tape, which government offices used in those days to bundle papers and the like. This "red tape" gave rise to the expression "government red tape." Patent models were used to highlight the invention in a visual manner and their display at the Patent Office showed the evolution of technology during these early years.

The U.S. Patent Office Model Museum

The models were proudly displayed in the Patent Office Building Model Museum, located on "F" Street in Washington, D.C. There, in its four magnificent architectural wings, these beautiful examples of American progress were exhibited in rows of glass cabinets. People throughout the world came to view these miniature examples of patented inventions. To the inventor, the idea of potential investors or manufacturers studying his or her patent model offered a great incentive to craft a highly detailed model that would stand out on the crowded model museum shelves. Today, this still beautiful building houses the Smithsonian Institution's American Portrait Gallery.

In 1880 the Patent Office dropped the requirement for submitting models. From that time forward the Patent Office relied only upon the inventor's submitted drawings and specifications in granting patents. This action was taken primarily because the Patent Office had simply run out of space in which to display the mass of models. Inventions were also becoming more complex and less amenable to be represented by models. Once the requirement for submission of a model was rescinded, a decline was immediately seen in the number of professional model makers working in Washington, D.C. After 1893, public interest in the model museum declined as other museums became popular.

Before the Smithsonian Institution acquired portions of the model collection from the Patent Office, the models had suffered through two major fires at the Patent Office. The first, in 1836, destroyed all the models that had been submitted up to that date (approximately 7,000). Not only were all the models lost, but all of the 9,000 patent drawings and records of patent applications and grants were also destroyed. These records were critically important, and the U.S. Congress appropriated \$100,000 to restore the drawings and the most important models. During the restoration process the Patent Office met with the original inventors when possible to ensure an accurate reproduction was made of each invention. This restoration program continued until 1849, by which time several thousand drawings and models had been recreated. Prior to the 1836 Patent Office fire, patents had not been numbered. After the 1836 fire, patent models began to be numbered consecutively. Restored patents were given a series of new numbers called the "X-series." A second fire in 1877 destroyed about 75,000 models out of a collection, by that time, of more than 200,000.

In 1908 the Smithsonian Museum patent model collection was started with the acquisition of 284 models from the Patent Office. In 1912 Congress attempted to sell what was left of the patent model collection, but had no bidders. The Patent Office models were hastily packed into more than 3,000 large, wooden storage crates and stored in buildings throughout the nation's capital.

In 1926 Congress decided to eliminate the storage expenses for the models and to sell them to the highest bidder. Before the auction took place, the Smithsonian Institution was given an opportunity to salvage some of the most significant models, and it also assisted in returning some of the models to the inventor's families or to the companies the models had helped to launch. Unfortunately the models had not been organized or inventoried when packed and the task of finding the critical models proved difficult causing many important models to be left behind. The Secretary of the Smithsonian, Charles Doolittle Walcott, appointed two curators, Frederick Lewton and Carl Mitman, to select the historically important models. Mitman chose models specifically for the mechanical engineering collection, while Lewton selected a broader range of models. The collected models were then assigned to various divisions within the Smithsonian Institution. Over the years some of the patent models were shown either permanently or within specific short-term displays. However, most of the patent models remained in storage within the various Smithsonian Museums and Divisions and are seldom, if ever, seen by the public.

At the auction the majority of the models were disposed of as one lot to high bidder, Sir Henry Wellcome, founder of the famous pharmaceutical company, Burroughs Wellcome. He hoped to establish a museum for the models but died before that could be accomplished, and the executors of his estate sold his entire collection.

Analysis of the Lighthouse Related Patent Models

In 2010 the Smithsonian's National Museum of American History (NMAH) produced a study of the patent models within their collections and released a Patent Model Index. The US Lighthouse Society reviewed the Patent Model Index and all patent models associated with lighthouses were identified. In addition we located one patent model in a private collection that is lighthouse related. The actual patents were then downloaded from Google Patents and the following listing was compiled.

Patent Number	Invention Name	Inventor	NMAH Division	Year
1934	Lamp, Argand	Hemmenway	Domestic Life	1841
2039	Lamp, Argand	Greenough	Domestic Life	1841
3692	Lamp, Lighthouse	Lewis, Sr.	Domestic Life	1844
14492	Lamp, Oil Regulator	Coates	Domestic Life	1856
25611	Burner, Incandescent Gas	Smith	Domestic Life	1859
109303	Burner, Paraffine	Doty	Domestic Life	1870
148909	Burner, Gas	Wigham	Private Collection	1874
177825	Lamp Burner, Lighthouse	Funck	Domestic Life	1876
190979	Light, Floating Signal	Pintsch	Domestic Life	1877
204806	Lamp Self Lighting, Lighthouse	Forrest	Domestic Life	1878

The Society then contacted the museum curatorial staff and obtained photographs of each of the models in the collection associated with the lighthouse patents. Below you will find each patent description with its associated patent drawings and the photograph of its patent model. We have also included a short description of how the particular patent was used (or not used) as an element of lighthouse technology and in some cases where further information can be found about its use.

UNITED STATES PATENT OFFICE.

BENJAMIN HEMMENWAY, OF ROXBURY, MASSACHUSETTS.

CONSTRUCTION OF ARGAND LAMPS.

Specification of Letters Patent No. 1,934, dated January 20, 1841.

To all whom it may concern:

Be it known that I, BENJAMIN HEMMENWAY, of Roxbury, Norfolk county, State of Massachusetts, have invented new and useful Improvements in Argand Lamps.

The said improvements, the principles thereof, manner in which I have contemplated the application of the same by which they may be distinguished from other inventions of a like character, together with such parts or combinations, I claim as my invention and for which I solicit Letters Patent, I have herein set forth and described, which description taken in connection with the accompanying drawings herein referred to, and which exhibit my invention, forms my specification.

Figure 1, represents an elevation of the exterior of an Argand lamp with my improvements. Fig. 2 is a vertical section of the same exhibiting the construction of the interior.

In general in all the Argand lamps now in use it is necessary to remove and invert the oil chamber in order to replenish it with oil; the same being usually connected to the body or stand by a screw. This operation, besides its inconvenience and its tendency to cause a derangement of the connecting parts from wear incident thereto, is generally attended with the accident of an overflow or dropping of oil on the exterior of the lamp.

The object of my improvement is to render the removal of the oil fountain unnecessary, and to provide a very simple method of resupplying the same with the combustible fluid.

A, Fig. 2 represents the oil reservoir, and B the air chamber, situated immediately under the same in the body of the lamp. The oil chamber has a short tube C projecting from its top. This tube has a screw cut on that portion of its outer surface which is above the top of the oil chamber, on which a hollow milled nut or cap D is screwed. A leather washer E is interposed between the top of the tube C and the bottom of the interior of the nut. On removing the cap D, the reservoir A may be filled with oil through the tube C; and on firmly screwing down the cap D, the washer E prevents the entrance of any air, into the reservoir A, through the tube C. The reservoir A communicates with the air chamber B by a tube F, inserted in the bottom plate G of the former, as seen in the drawing.

This tube has a stop cock H therein the head or handle of which projects on the outside of the air chamber, so that by applying the hand thereto, it can be turned at pleasure. The shank of the air cock, where it passes through the side of the air chamber B should be well fitted therein. A tube K, open at both ends passes downward through the reservoir and is soldered into the top and bottom of the same; leaving a free passage for the external atmosphere through the tube into the air chamber B. The other parts of the lamp are the same or similar in their construction to those in common use.

From the above it will be observed that in order to fill the reservoir A with oil, it is only necessary to close the stop cock H, there by shutting off the communication between the reservoir and air chamber B. Then unscrewing the cap or nut D, the oil may be poured through the tube C. On closing the passage C by firmly screwing down the cap D, and opening the cock H air will ascend through the tube F, causing the oil to pass downward through the tube into the air chamber B, and will rise in the said air chamber to the level of the bottom of the tube F. Then as the oil is gradually consumed by the flame of the wick, its surface in the air chamber will fall below the bottom of the tube and permit a small quantity of air to rise into the reservoir A, at the same time displacing an equivalent body of oil, which descends into the air chamber.

I claim—

Combining with the air chamber B, in the manner set forth, a tube K for admitting air to said chamber and a stationary fountain or reservoir for containing oil constructed as described, that is having a tube to admit of a supply of oil when necessary, with a cap adapted to said tube to exclude the pressure of the air, and a tube F for conveying the oil to the chamber B provided with a stop cock to intercept the communication while the fountain is being filled; all as set forth.

In testimony that the above is a true description of my invention I have hereto set my signature this sixth day of October in the year eighteen hundred and forty.

BENJAMIN HEMMENWAY.

Witnesses:

R. H. EDDY,
EZRA LINCOLN, Jr.

B. HEMMENWAY

Lamp.

No. 1,934.

Patented Jan'y 20, 1841.

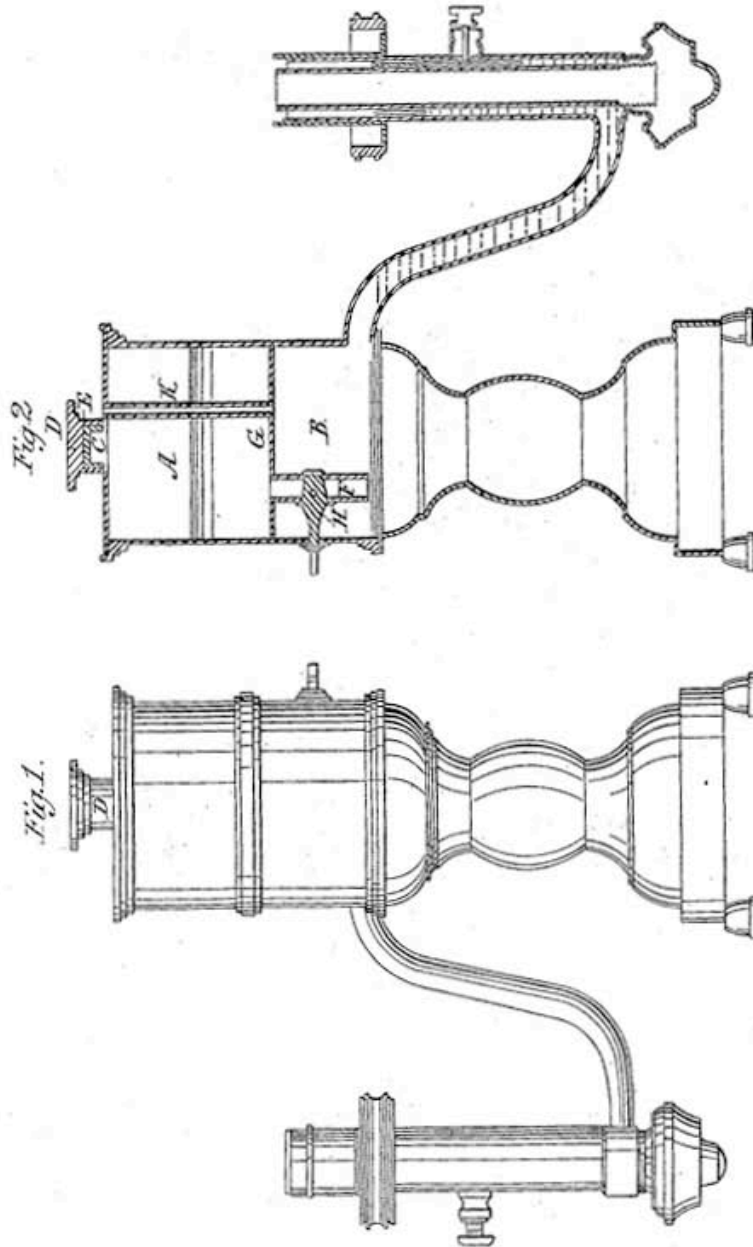

Benjamin Hemmenway, a coppersmith and manufacturer of lamps, designed this lamp (Patent 1934) as a constant level lamp that could be used with reflectors in lighthouses. The design lent itself well to be placed behind a reflector with only the lamp burner and glass chimney inside the reflector. Hemmenway had a relationship with Winslow Lewis and he began making lamps and reflectors for Mr. Lewis in the 1820s. By 1835 Hemmenway was making all of the lamps for Winslow Lewis.



(Photo Courtesy Smithsonian Institution, National Museum of American History, Home and Community Life)
RWS2012-04600 Patent 1934 Argand Lamp (Base Only).

UNITED STATES PATENT OFFICE.

BENJAMIN F. GREENOUGH, OF BOSTON, MASSACHUSETTS.

LAMP.

Specification for Letters Patent No. 2,039, dated April 10, 1841.

To all whom it may concern:

Be it known that I, BENJAMIN F. GREENOUGH, of Boston, in the county of Suffolk and State of Massachusetts, have invented
5 new and useful improvements in lamps for burning chemical mixtures or compositions of alcohol, spirits of turpentine, and such other matters or fluids as are generally substituted for common oil, and that the
10 following is a full and exact description of the same, reference being had to the accompanying drawings, which, taken in connection herewith, form my specification setting forth the principles of my invention, by
15 which it may be distinguished from others of a like character, and such parts or combinations thereof as I claim and for which I solicit an exclusive property to be secured to me for fourteen years by Letters
20 Patent.

Figures 1, 2, 3, Plate 1, represent the burner of a lamp with my improvement applied thereto. Fig. 1, being an elevation and Fig. 2, a vertical transverse section of
25 the same. Fig. 3, is a horizontal section of the burner inverted exhibiting the lower part of the cone and spring slide, by which it is adapted to the exterior tube of the burner, as will be hereinafter described.

30 My first improvement consists in the construction of the button *a*, Figs. 1 and 2, which serve to spread the flame of the wick. The heat caused by the current of air passing over both sides of the flame is so intense
35 as to often melt down, or soon burn out or destroy the button, if the same is made of brass, iron or copper in the usual manner. The button *a* is a small thin circular plate of platina, or other suitable material, hav-
40 ing a hole bored through its center, so that when it is placed on a shoulder *b*, Fig. 2, a small square or circular projection *c* from the top of the shoulder may pass through the same and retain it in place on said shoulder.
45 The shoulder is a conical or other proper shaped piece of metal, fixed on the top of the adjusting rod *d*, by having a hole in its lower side, and inserting the rod therein as seen in Fig. 2. The shoulder *b*
50 being smaller in diameter than the circular platina plate *a*, it is therefore situated at such a distance from the flame as not to be liable to serious injury therefrom. Should it ever be necessary to renew the plate, the
55 same can be easily effected at any time, by removing it and substituting another, as will

be seen by the peculiar construction of the shoulder sustaining it. It is found, that the conical shoulder so formed, is a great preservative of the button, as when simply laid
60 upon the same, it does not oxidate so soon as when attached to the top of the rod which supports it in the usual way.

My second improvement consists in supporting and guiding the adjusting rod *d*
65 upon which the button is placed by passing the same through a tube *e f*, Fig. 2, whose lower end *f* is screwed, soldered or otherwise properly attached to the bottom of the oil cup *A* as seen at *i*, Fig. 2. By turning a
70 milled head *h* on the lower extremity of the screw *g* of the rod, the rod, and consequently the button *a* is elevated or depressed at pleasure. Heretofore it has been customary to guide the upper part of the rod *d*,
75 by inserting the same through a hole in a small circular piece of metal, which latter was attached to the inner tube *B* of the oil chamber, by two or more bars or arms or projections proceeding there-
80 from and attached to the inner circumference of the tube. The cylindrical current of air, in passing upward around the rod *d* had to pass through the spaces between the arms above mentioned and therefore was divided
85 into two or more currents with such intervals between them, as produced a great irregularity or inequality in the height of the flame. This evil is corrected by supporting the rod by means of a tube *e f* in
90 manner above described. The current of air, rushing through the tube *B*, being uninterrupted acts equally on the whole interior of the flame, and thus causes a more brilliant light to proceed therefrom than can other-
95 wise be produced. The exterior tube *C* of the burner is somewhat larger in diameter than the interior and concentric tube *B*. They are properly connected together at bottom and have the oil cup *A* attached to
100 them in the usual manner. The oil or chemical mixture to be burned, is introduced into the space between the tubes *B* and *C* through a pipe *D*, Figs. 1, and 2, proceeding from the fountain or reservoir and inserted in the
105 outer tube. The wick *k k* is passed rather tightly over the outer circumference of a tube, *l*, a very little larger in diameter than the tube *B*, and the said tube *l* being dropped into the space between the tubes
110 *B*, *C*, rests on the bottom *m m* of said space, its top projecting about one-sixteenth of an

inch above that of the outer tube C, as seen in Fig. 2.

My third improvement consists in the method of adapting the cone or conductor (through which the exterior current of air rushes which impinges on the flame), to the tube C, by which the position or elevation of the top of said cone, with respect to the button *a*, may be easily adjusted. This is effected by applying a short spring tube E, Figs. 1, 2, 3, Plate 1, upon the outside of the exterior tube C of the burner and connecting the cone to the tube C by a series of arms F F, Fig. 3, extending from one to the other. The air rushes upward through the spaces between the arms. The tube E fits closely upon the tube C, and has several slits G G, as seen by dotted lines in Fig. 1, cut vertically in its circumference, so as to convert the tube into a spring, by the pressure of which, upon the outer tube of the burner, the cone is sustained at any elevation thereon. The above adaptation of the cone is of peculiar importance; when used in connection with the adjusting button *a*, whether constructed of platina or in the usual manner, for the elevation of the button, determining the divergence of the frame, the cone requires to be raised or lowered in accordance therewith to such distances as will cause the outer current of air to impinge upon the flame in such manner as to produce the greatest effect. Therefore it will be seen that a movable cone is essential to an adjusting button, and the combined action of the two produces better light than when the cone is fixed or rests on a shoulder as in ordinary lamps. The cone has a shelf or rim H H, around its lower edge, upon which the glass chimney is placed in the usual manner.

Figs. 1 and 2, Plate 2, represent a lamp with other improvements, the former being an elevation and the latter a vertical section of the same.

In this kind of lamp it will be perceived that the cone A has a very extended base B, arranged on the lower part of the same, the said base being cylindrical and in diameter somewhat larger than the lower part of the cone where the same is cemented to it. Through the entire circumference of this base a series of holes *a, a, a*, is bored very close to each other. The cone, thus formed, is placed on the top C of the oil fountain D, as seen in the drawings, and is sustained in position by being dropped into a circular socket *h h*, formed or cut down in the top C to the depth of about one-sixteenth of an inch. The chimney E placed on the outside of the cone rests on the shelf *c c* or top of the extended base B as seen in Fig. 2.

As the top of the ground glass globe or shade fits rather closely around the chimney, the bottom of the globe or shade should be

supported somewhat above the top C or on a level with the top of the holes *a, a, a*, by small studs or bent standards *d d* or other similar contrivances affixed on the top C of the oil fountain. From the above it will be seen that the air rushes under the glass globe, and thence passing through the holes *a, a, a*, as denoted by arrows, Fig. 2, and taking a direction toward the center or axis of the cone unites in a circular column, as it reaches that part of the lower portion of the cone, which causes it to pass upward. It thus rushes toward and impinges on the exterior of the flame in an uninterrupted circular current, a desideratum highly desirable in lamps of this kind, as it will be perceived by inspection of Fig. 3, Plate 1, that the arms F F divide the current of air.

In order that the several currents of air passing through the holes *a, a*, formed around the circumference of the cylinder B, attached to the lower part of the cone may properly unite together in one circular current as they bend upward to pass toward the flame, the circumference or rim of the cylinder B, should be of such size that the sum of the widths of all the holes, bored at regular distances apart through the same, shall equal the inner circumference of the cone where it is joined to the cylinder B. Therefore the several currents would meet together as they pass into the cone. The cone is represented above as stationary, but it can be easily adapted to a lamp, so as to be movable up and down, or adjusted as regards its position. In this case, the cone should be formed in all respects substantially as seen in Figs. 1, 2, Plate 2, and should rest on a circular shelf *a*, Fig. 3, Plate 2, which is adapted to the outer tube *h* of the burner by a circular tube spring *e*, arranged and operating like the spring E, Fig. 1, Plate 1. The circular shelf *a* is solid or has no air passage through the same, so that the air of which the external current is composed rushes through the holes of the cone and unites as before described. If the lamp is also constructed with an adjusting button guided by a tube in manner as before mentioned, the flame will be supplied with an external and internal uninterrupted current of air, by which its brilliancy will be much improved.

Having thus described my invention I shall claim—

1. The placing of a shoulder on the rod by which the button is supported, said shoulder being so constructed as to set loosely on said rod, and adapting the button to a projection on said shoulder in a similar manner, by means of which combined arrangement the rapid oxidation of the disk is prevented, all as herein set forth.

2. Guiding the adjusting rod of the button by passing the same through a tube

whose lower end is attached to the bottom of the oil cup, or otherwise similarly arranged, the said tube extending upward into and through the central part of the interior tube of the burner, the whole being for the purpose of permitting an uninterrupted current of air to act on the inner surface of the flame as above set forth.

3. The combination of an adjusting cone, (applied to the exterior tube of the burner by a circular spring or other contrivance substantially the same, by which its altitude can be regulated), with the adjusting button, or one whose elevation may be varied at pleasure, the whole being arranged substantially in manner and for the purpose above mentioned.

4. Lastly I claim a cone constructed with an extended cylindrical base, having a series of radial holes through the circumference of the same, and made so as to be adjusted

in height on the exterior tube of the burner by means of a circular shelf and spring, in combination with a movable button, whose rod is supported and guided by a tube, connected with the oil cup and whose elevation can be regulated by a screw or other suitable contrivance, the whole being constructed and arranged substantially in manner and for the purpose of supplying the flame with an uninterrupted circular current of air on each side thereof, as above set forth.

In testimony that the above is a true description of my said invention and improvements I have hereto set my signature this seventeenth day of March in the year eighteen hundred and forty-one.

B. F. GREENOUGH.

Witnesses:

R. H. EDDY,
EZRA LINCOLN, JR.

B.F. Greenough,

Sheet 1-2, Sheets.

Lamp,

No. 2,039,

Patented Apr. 10, 1841.

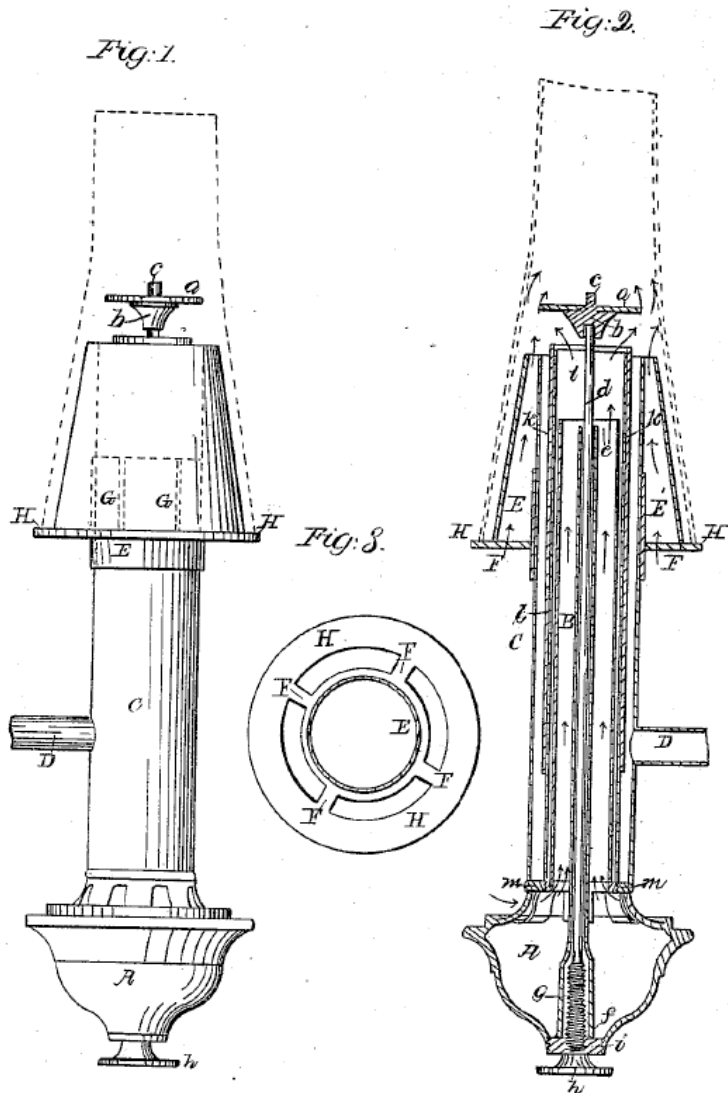

B.F. Greenough, *Sheet 2 of 2 Sheets.*

Lamp,

No. 2,039,

Patented Apr. 10, 1841.

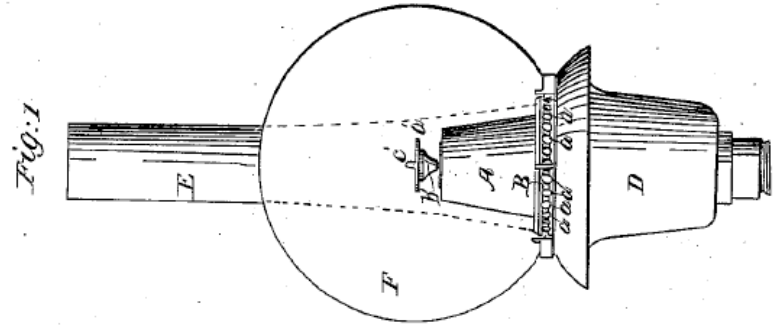
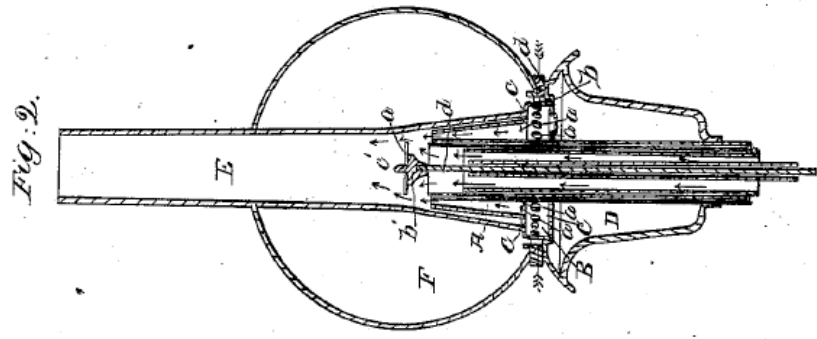
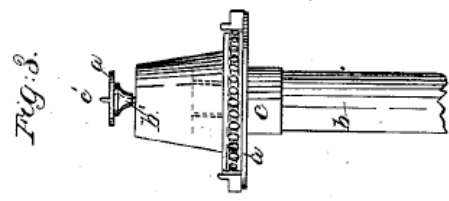

This lamp, Patent 2039, was designed by Benjamin Greenough to try Camphene as a fuel in lighthouses. Camphene is a hydrocarbon obtained from a blend of turpentine and ethyl alcohol. In 1840, Stephen Pleasonton authorized Mr. B. F. Greenough to begin tests of what he called 'Chemical-Oil', at the Boston lighthouse as a potential lighthouse fuel. Chemical-Oil was the name Mr. Greenough used for the substance Camphene. It was noted in the experiments at Boston light that the Chemical-oil burned with intense brilliancy, greatly surpassing Sperm-Whale oil. Mr. Greenough patented his lamp, which had many advanced features, on April 10, 1841. Mr. Greenough also offered to fit his lamp, using Camphene as the fuel, in the tests of the first Fresnel lenses imported by the U. S. Government. Stephen Pleasonton later reported:

"I have made a trial of Camphene, by Mr. Greenough, at Boston. The Camphene afforded a beautiful light, but after the lapse of a few months it became decomposed, and was not fit for use."



(Photo Courtesy Smithsonian Institution, National Museum of American History, Home and Community Life)
RWS2012-04606 Patent 2039 Argand Lamp (Burner Only).

UNITED STATES PATENT OFFICE.

WINSLOW LEWIS, OF BOSTON, AND BENJN. HEMMENWAY, OF ROXBURY, MASSACHUSETTS.

LIGHT-HOUSE LAMP.

Specification of Letters Patent No. 3,692, dated August 7, 1844.

To all whom it may concern:

Be it known that we, WINSLOW LEWIS, of Boston, in the county of Suffolk, and BENJAMIN HEMMENWAY, of Roxbury, in the county of Norfolk and State of Massachusetts, have invented a certain improvement in lamps to be used in light-houses, the same being more particularly valuable for them than for other purposes, and that the following description and accompanying drawings taken together constitute a full and exact specification of the construction and operation of our invention.

Figure 1, of the drawings above-mentioned, represents a side view of an Argand lamp, such as is now generally used in the lighthouses, on the coast of the United States. Fig. 1, is a longitudinal, central and vertical section thereof.

As these lamps have heretofore been constructed, the tube A, (Figs. 1, 2,) which proceeds from the oil fountain B, to the burner C, has been always soldered firmly to the burner, or so attached thereto that the burner could not be separated from it without rupturing the soldering, or sawing off the tube where it joins the burner. In our improved lamp, the burner is connected to the tube A, or the fountain by a double coupling screw or joint D, such as is generally used to connect gas tubes together. By this means all that will be necessary to remove the burner, is simply to sufficiently unscrew the coupling. We are thus enabled to separate the burner from the tube, and by so doing to more effectually clean it whenever the same may be required.

In the common Argand lamp, heretofore used in lighthouses, the inner air tube E, Fig. 2, on which the thimble carrying the wick traverses, is made of brass, or composition metal. The top of this tube, coming into contact as it does with the flame of the wick is so completely destroyed in about two years, as to require its condemnation, and the substitution of a new burner, or tube at an expense generally speaking of three dollars and upward. Experience has proved that every part of the lamp, except that which comes in contact with the flame as before mentioned, will wear when used constantly in a lighthouse, somewhere about sixteen years, without requiring any material repairs. Consequently it will be seen that any contrivance by which the destruc-

tion of the inner air tube of the burner, can be prevented, must be very useful and valuable. As a remedy for this, we make the tube in two parts viz, *a, b*, as seen in Fig. 2, the top part *a*, being a short tube or ferrule about an inch in length, and of the same external diameter as that of the lower part, and fitted upon the lower part, so as to be placed thereon, or removed therefrom (when placed thereon) at pleasure. The top of the lower part of the tube, is turned down for a short distance, so as to receive the upper part or ferrule, and permit it to rest upon a shoulder at *c, c*. It is this ferrule therefore against which the flame acts, and which when injured or destroyed can be easily removed and a similar one substituted without requiring the removal of the whole burner as above set forth. Our burner is further constructed so that the ordinary rim, or shelf, of the glass holder, (which in some measure obstructs the light) is dispensed with, the wick being raised or lowered without turning the chimney or lamp glass as in most other lamps wherein the chimney is constantly liable to and often does come in contact with the blaze and thereby becomes smoked upon its interior surface. The chimney F, in our lamp, is supported upon three or more, small brackets, or projecting pieces of metal, (two of which are represented at G, G, Fig. 1) soldered to the exterior surface of the outer tube of the burner, and extending upward about three quarters of an inch above a milled head or rim H, formed upon the lower part of the movable tube I, which constitutes part of the apparatus for raising and depressing the wick. Each of the brackets G, has a right angled shoulder *d*, formed upon its outer edge just above the milled rim H, as seen in the drawings, the several shoulders constituting supports for the glass chimney to rest upon, as seen in Fig. 2. By applying the fingers to the milled rim of the tube I, the tube may be turned around, so as to cause the wick apparatus, to elevate, or depress the wick according to the direction in which the tube is moved.

The mode of arranging the lamp glass or chimney upon supports attached to the outer tube of a cylindrical burner, (instead of supporting the chimney upon a shelf or the milled rim of the tube I, as in ordinary Argand lamps,) and which (supports) so

extend above the milled rim H, as to sustain the chimney above the same, thereby permitting the fingers to have between the said supports or brackets, free access to the milled rim we believe has never before been effected. The advantage of this mode of sustaining the chimney, with respect to the tube I, consists in its maintaining its fixed position, whenever the tube is moved horizontally either in one direction or, in the opposite. As it does not turn with the tube I, when once regulated so that the flame and smoke will pass directly through its center, it always maintains its position, and thereby is not liable to become smoked, whenever the tube I, is turned by the fingers applied to its milled rim.

It is seldom that a lamp glass is constructed with its bottom edge in a plane perpendicular to its axis, and therefore when placed upon the burner its position generally requires adjustment in order to prevent it from being smoked. A derangement of such position which is very likely to occur whenever the fingers are applied to the burner to elevate or depress the wick, often so inclines the glass chimney as to bring the upper part of its interior surface in contact with the flame and smoke. Lamps are often constructed with stationary chimneys, but in such the wick has been raised and lowered by a contrivance different from the tube I.

Having thus described our invention,

what we claim and desire to secure by Letters Patent is, as follows, viz:

1. A movable cap, or ferrule applied to, or slipped upon the inner air tube of the burner for the flame to act upon, instead of against the top of the inner tube as heretofore arranged.

2. Also the above described mode of sustaining and arranging the supports of the glass chimney, with respect to the tube I, and milled rim thereof by which, in connection with the other mechanism the wick is elevated and depressed; the ordinary kind of glass holder being thereby dispensed with and the wick raised and lowered without turning the chimney, or lamp glass; thus preventing the chimney from being smoked on one side, or, its interior surface, as often takes place in lamps, where it is supported upon a glass holder as ordinarily constructed; the whole of the above being substantially as hereinbefore explained.

In testimony that the foregoing is a correct specification of our said invention, we have hereto set our signatures this twenty-seventh day of June in the year of our Lord, 1844.

WINSLOW LEWIS.
BENJAMIN HEMMENWAY.

Witnesses:

R. H. EDDY,
DAVID A. GRANGER.

LEWIS, Sr. & HEMMENWAY.

Lamp for Light Houses, &c.

No. 3,692.

Patented Aug. 7, 1844.

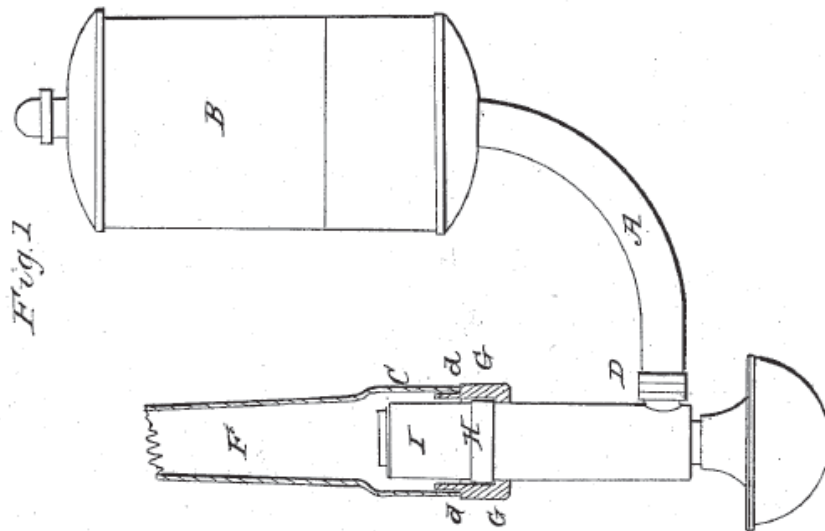
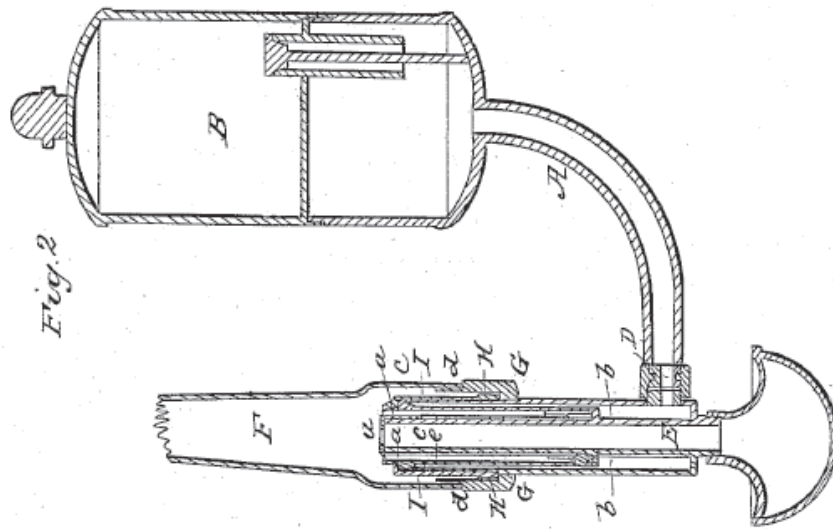

The lamp designed by Benjamin Hemmenway and Winslow Lewis in 1844 became the standard lamp used within reflectors from that time until the end of the Winslow Lewis era. It was used from 1844 through 1852 and was only superseded when the Lighthouse Board began the installation of Fresnel Lenses late in 1852. For more information see The Keeper's Log Vol. 15, No. 1, *Early American Lighthouse Illumination*.



(Photo Courtesy Smithsonian Institution, National Museum of American History, Home and Community Life)
RWS2012-04603 Patent 3692 Lighthouse Lamp.

UNITED STATES PATENT OFFICE.

ABRAHAM COATES, OF NEW YORK, N. Y.

IMPROVEMENT IN REGULATING THE FLOW OF OIL TO THE WICK IN CARCEL LAMPS.

Specification forming part of Letters Patent No. 14,492, dated March 25, 1856; Reissue No. 643, dated January 4, 1859.

To all whom it may concern:

Be it known that I, ABRAHAM COATES, of New York, in the county of New York and State of New York, have invented an Improvement in Regulating the Flow of Oil to the Wick in Carcel Lamps for Light-House Purposes; and I do hereby declare that the following is a full, clear, and exact description of the principle or character which distinguishes it from all other things before known, and of the usual manner of making, modifying, and using the same, reference being had to the accompanying drawings.

Figure 1 represents a vertical section through the whole apparatus; Fig. 2, a detached perspective of part of the lamp; and Fig. 3 represents a vertical section through the regulator.

My invention consists, first, in a mode of regulating the flow of oil to the wick in that class of lamps known as the "Carcel" lamp, or lamps in which the oil is made constantly to overflow the wick-tube, the construction and operation of which is as follows; and, second, in a mode of heating the oil for light-houses, as hereinafter described.

The lamp is designed chiefly for light-houses. The reservoir or fountain *a* is elevated at the height proper to give the required pressure, and within this is a siphon, *b*, the short leg of which terminates above the bottom of the reservoir, the long leg passing through the bottom of the reservoir and down to the wick-tube *n* of the lamp.

The object of the siphon-tube is to avoid impurities of the oil, which settle at the bottom of the fountain.

The flow of oil to the wick is regulated by the following automatic contrivance: In an enlargement, *e*, of the siphon-tube is a valve, *e'*, which is opened and closed by the axis of the gimbal *e''*, connected with the balance-lever *h*. At one end of this lever is an adjustable weight, *i*, and at the other end a waste or drip cup, *k*. The waste-tube *t* conducts from the burner the overflowing oil to the drip-cup. The drip-cup is provided with a strainer to clean the oil, so that it may flow uniformly through the aperture *m*.

The self regulation is effected as follows: The drip cup is charged with oil to such an extent that with the adjustment of the weight *i* the valve *e'* will be sufficiently open to furnish the proper supply to the wick and waste through tube *t*. The set-screws *s*

are then adjusted so that the lever will not move so far in either direction as to cause either an excess of supply or cut off altogether. If from any cause the oil should flow too fast, it will fill the drip-cup faster than it can empty itself through aperture *m*, and the increased weight of the cup will cause that end of the lever to descend and diminish the valve-opening and lessen the supply. The cup will then empty itself to its proper level, return to its proper position, and thus regulate the flow of oil. If from any cause the flow should be too slow, the cup will empty itself faster than the cup is supplied with oil, and the consequence will be a further opening of the valve and a greater supply. It is important to the success of this mode of regulation that the oil should be kept pure.

The mode of heating the oil is as follows: The reservoir or fountain *a* is placed over or upon the top of the Froesnal lens *A*, and has a passage, *B*, through its center for the escape-draft of the lamp within the lens. A part of the vessel *a* descends within the lens, as seen at *a'*. By this arrangement the oil in *a* is kept constantly heated, and the fountain does not interfere at all with the operation of the lens.

It is not only an advantage at all times to keep the oil heated, but an economical arrangement for heating the oil, like that above, is of great importance in light-houses, where the oil is exposed to such intense cold. It will be seen by this arrangement of the fountain and the supply-pipe *d*, which is wholly within the chamber of the lens, that the oil is not exposed to any cooling influence on its passage from the fountain to the lamp.

What I claim as my invention and improvement in lamps in which the oil is forced to the wick so as to overflow is—

1. Regulating the supply of oil to the burner by means of the self-emptying drip-cup, operating upon the supply-valve, as herein set forth.

2. Placing the fountain or reservoir for the oil above the lens, with its draft opening *B* and its supply-pipe *d*, within the barrel or chamber of the lens, all arranged and operating substantially as set forth.

ABR. COATES.

Witnesses:

CHAS. G. PAGE,
WM. H. HARRISON.

A. COATES.

Lamp.

No. 643.

Reissued Jan. 4, 1859.

Fig. 1

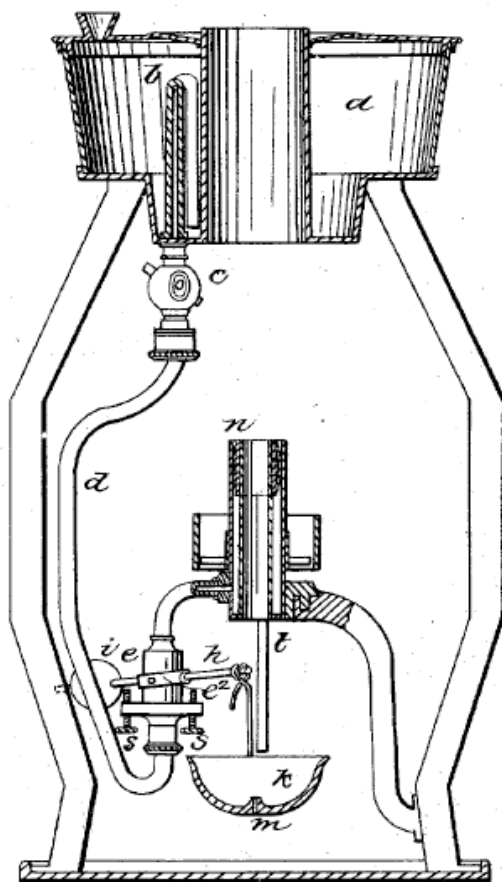

Fig. 3

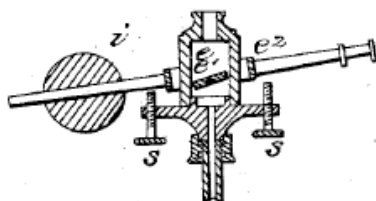
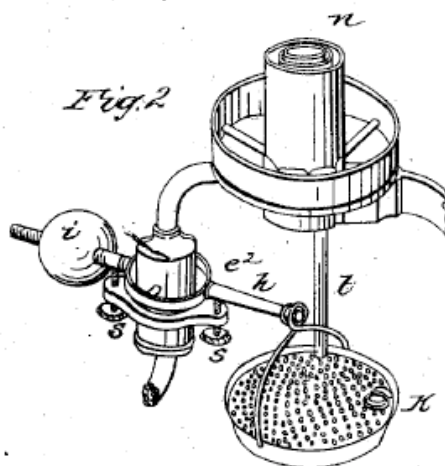

Fig. 2



The Coates Lamp was the prototype for what became known as the Franklin Lamp and was used in 4th, 5th and 6th order Fresnel Lenses. For more information see The Keeper's Log Vol. 19, No. 1, *From Braziers and Bougies to Xenon*.



(Photo Courtesy Smithsonian Institution, National Museum of American History, Home and Community Life)
RWS2012-04601 Patent 14492 Oil Regulator Lamp.

UNITED STATES PATENT OFFICE.

GEORGE HAND SMITH, OF ROCHESTER, NEW YORK, ASSIGNOR TO SILAS O. SMITH, OF SAME PLACE.

APPARATUS FOR THE PRODUCTION OF HARE'S HYDRO-OXYGEN LIGHT.

Specification of Letters Patent No. 25,611, dated September 27, 1859.

To all whom it may concern:

Be it known that I, GEORGE HAND SMITH, of Rochester, in the State of New York, have invented a new and useful Improvement in Lights for Locomotive-Engines, Lighthouses, &c.; and I hereby declare that the following is a full, true, and exact description thereof, reference being had to the accompanying drawings, and to the letters of reference marked thereon, which are made part hereof, and of which—

Figure I is a vertical section, and Fig. II a top view of the end of the arm B containing the gas-burners or jets, the letters of reference to each part being the same in both drawings.

Lights, in general, are of two classes: first, those arising simply from a flame—no matter how produced—as in candles, ordinary oil and spirit lamps, common gas lights, or Garney's "bride light;" and second those arising from a solid incandescent surface, of which the "Drummond" and electric lights are representatives. In the former of these two classes improvements have been made by throwing a stream of oxygen upon a flame derived from oil or naphthalized gases, &c., or by exposing to combustion ordinary atmospheric air saturated with hydro-carbons. In the second class little if any improvement has been made upon the Drummond light, which consisted of a fragment of lime, or similar material, made incandescent under the operation of the oxyhydrogen blowpipe. An attempt was made by Gaudin to combine these two classes by exposing a piece of magnesia, hung on a platina thread, to the impact of a flame arising from the combustion of ether or alcohol, and increased by the addition of oxygen driven into it by the pressure of mercury. These outlines, it is believed, indicate the principle of most—if not all—improved lights known until the present time. None of them, if successful to any extent, have been sufficiently so to be permanently or generally used for any purpose beyond lighting large halls, &c.; and all are subject to great, if not insuperable, objections, among which may be stated the choking of tubes, and the great and expensive amount of combustion of materials, and the difficulty of regulation, of the "bride" class of lights; and the difficulty and expense of producing hydrogen, its dan-

gerously explosive character, and the great weight of machinery required, in the "Drummond" light class. While, in addition to these reasons, the use of any of these improved lights was next to impossible on locomotive engines, owing to the jarring character of their motion and the difficulty of regulating the draft and supply of air to the point of combustion, in any lantern, or lighting apparatus, placed in the very front of an engine moving with great velocity through the air, in all weathers and all directions.

To obviate these difficulties, and to supply an intense light, equally fitted for stationary use, or for service on locomotive engines, and other bodies, moving irregularly, at high rates of speed, and in entire disregard of atmospheric circumstances, has been my object; and this I claim to have done as follows:—

From a sufficient support, A, of any form or character, I project the arms B and C. The arm B contains within it the supply pipe D, by which the combined gases (presently specified) are fed to the burners E E, &c.

F is a hollow tube or barrel (which I usually make about half an inch in diameter), at the bottom of which is a plunger worked by a nut H and screw G, and so elevated or lowered. Upon this plunger and within the barrel F is placed a "radiator" K, of lime or magnesia of any size and shape required to fit the barrel F easily. I prefer to use a cylinder an inch and a half long by about seven-sixteenths of an inch in diameter. The burners E E, &c., are tubes, of capillary orifice—much less than the bore of the tube—springing vertically from the end of the arm B, which end is made circular (as shown in the drawings, Fig. II.), and through its interior the supply pipe D is led; with this supply pipe the burners E E, &c., communicate, and they are made of such a height that their upper ends which contain the orifice of discharge, and which are bent inward and upward, at an obtuse angle, toward a common center (at which center the radiator K is placed) shall be a little above the top of the barrel F. These burners E E, &c., I arrange as follows: If the circumference of the circular end of the arm B is divided into eighths, three burners are placed on the front side thereof so that

they occupy about one quarter of its circumference—being not over one eighth of such circumference apart from each other, and a fourth burner is placed diametrically opposite the middle one of the other three.

L L is a reflector which may be of any shape required; it is perforated below in order to admit the top of the barrel F, and the burners E E, &c.

I mix either oxygen, or ordinary atmospheric air, with carbureted hydrogen (as supplied from any local gas works) in such proportions as may be desired, but I prefer to use them in proportions varying between equality, on the one hand, and two fifths of the former with three fifths of the latter on the other hand. This mixing may be effected either by inclosing the gases in the same receiver, in the proportions desired, or by keeping them in separate receivers (which may be inclosed together) proportioned as required, and producing the mixture by allowing the gases to flow into the same pipe—which latter method I prefer. In either case the gases are condensed into the receiver before use until a sufficient amount of them is obtained, within the limits of the receiver or receivers, to supply the light for the time required and to insure the necessary flow.

In the course of the pipe through which the combined gases flow from the receiver, and before they reach the burners E E, &c., as above described, I place a gas regulator to govern their discharge.

The receiver for the gases may be of any shape or material fitted for the purpose; for use on locomotive engines it should be of metal, in order properly to resist the jarring motion, and, as condensed gases are used, it may be quite small.

The charging and condensation may be effected, in movable lights, by means of a force pump to be attached and detached at pleasure; in fixed lights, by hydrostatic pressure in ordinary gasometers, or by direct pressure on elastic bags.

The operation of my improvement is as follows: The combined gases flowing under heavy pressure, as described, and after being started through an ordinary stop cock, have their flow properly governed by passing through the gas regulator; they then enter the supply pipe D, and are fed to the burners E E, &c. The orifices of these burners, however, being, as described, considerably less in diameter than the tubes which they discharge, a re-acting pressure is here produced, by which—in combination with the gas regulator—a uniform flow, of much greater rapidity, force and volume than the normal discharge of the orifices, is permanently secured. From the burners E E, &c., the combined gases (then in combustion) impinge upon the radiator K, which, under

their operation becomes incandescent and intensely luminous. By the arrangement of the burners E E, &c., as before described, three strong jets of the combined gases are thrown on the radiator K, producing intense light at their neighboring and almost co-inciding points of impact, in front where it is most valuable, while the rear jet secures the incandescence, and even consumption, of the entire top of the radiator at the same time—a point of vital importance. Any other arrangement of the jets will either produce less light for the same consumption of the gases—or will consume much more gas for the same amount of light produced.

The advantages of this light, produced and operated as described, I assert to be these: 1. For the explosive hydrogen of the oxyhydrogen light—a gas which is notoriously expensive to obtain, dangerous to use, and requiring great chemical skill properly to supply,—it substitutes carbureted-hydrogen, which is cheap, easily and abundantly obtainable in almost every town of any size, always easily and expeditiously made, and entirely safe in manufacture and use as daily demonstrated. 2. Ordinary atmospheric air may be substituted for oxygen. 3. By means of condensation and consequent pressure, it on the one hand (by proper regulating machinery as described) secures an unvarying flow, of great power and volume from small orifices, and on the other hand reduces the weight and bulk of necessary machinery far below anything heretofore known in lights produced by incandescent surfaces. 4. No jarring motion is capable of affecting either the steady flow of the gases or the fixed position of the radiator. 5. It requires no regulation of draft or supply of exterior air, but may be inclosed in a draft-proof lantern, or behind a draft-proof lens; the combined gases supplying all that is necessary for its entire combustive operation; and so is entirely independent of atmospheric circumstances, or the rapidity and direction in which it may be driven. 6. By the arrangement of the burners as described the greatest possible amount of light is produced in proportion to the gas expended. 7. It consumes less of the incandescent mass than any other process of obtaining light from such an object. 8. It regulates itself and requires no trimming, &c., while in use.

The production of light from an incandescent surface, under the operation of one or more gases in combustion, is not new or claimed by me.

What I do claim is:—

1. The use of carbureted hydrogen gas in combination with atmospheric air or oxygen gas, in proportions desired, operating, under condensation, through a proper regulator, and discharging through jets of minute orifice, upon—and rendering incandescent—

any proper radiating material of any form, being independent of any atmospheric circumstances or situation,—in the manner and through the means and machinery substantially as hereinbefore described.

5 2. The arrangement of four jets or burners for directing the impact of gases on incandescent surfaces, such burners having minute orifices pointing to a common center, three of them placed so that their orifices
10 of discharge shall be within, or nearly within one quarter of the circumference of a

circle drawn through them from the center to which they point (being not more than one eighth of such circumference distant from each other), and the orifice of the fourth being diametrically opposite in such circle to the middle orifice of the other three, substantially as before described. 15

GEORGE HAND SMITH.

Witnesses:

DARIUS COLE,
J. M. SOUTHWICK.

G. H. SMITH.

Hydro Oxygen Light Apparatus.

No. 25,611.

Patented Sept. 27, 1859.

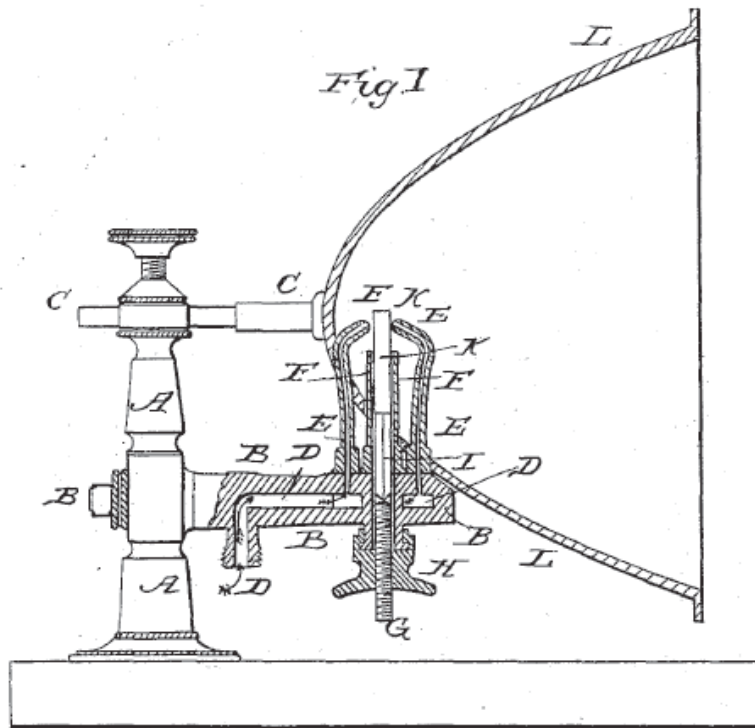
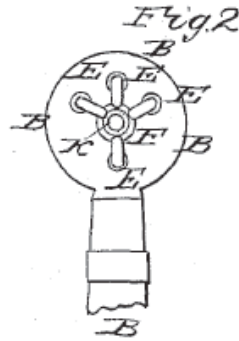

WITNESSES
H. Carpenter
John Haywood

INVENTOR
George Hand Smith

The Smith Hydro-Oxygen Apparatus was a modification of what was known as the Drummond Lime Light and Reflector. The Drummond lamp was named after Thomas Drummond and was extensively tried in England as a potential lighthouse lamp. While it produced a brilliant blue-white light it was very difficult to maintain. This style of lamp was also tried without success in America by the Lighthouse Board, but was never installed in a lighthouse.



(Photo Courtesy Smithsonian Institution, National Museum of American History, Home and Community Life)
RWS2012-04598 Patent 25611 Incandescent Gas Burner.

UNITED STATES PATENT OFFICE.

HENRY HARRISON DOTY, OF LONDON, ENGLAND.

IMPROVEMENT IN APPARATUS FOR BURNING PARAFFINE AND OTHER HYDROCARBON OILS.

Specification forming part of Letters Patent No. 109,303, dated November 15, 1870.

To all whom it may concern:

Be it known that I, HENRY HARRISON DOTY, of London, in the Kingdom of England, have invented new and useful Improvements in Means or Apparatus for Producing the more Complete Combustion of Paraffine and other Hydrocarbon Oils; and I do hereby declare that the following is a full and exact description thereof, reference being had to the accompanying drawings and to the letters of reference marked thereon.

This invention relates to a lamp for producing the more complete combustion of paraffine and other hydrocarbon oils; and consists in combining air-conducting cylinders with the wick-holder, and with a receptacle for oil, and brackets for the support of the chimney, rack, and pinions for operating the wick-holder and chimney-bracket.

A series of tubes or cylinders of different diameters, corresponding with the number of burners, are arranged vertically, one within the other, and uniformly brazed or soldered at the lower end to a plate or disk in such manner as to leave alternate air and cotton or wick spaces, the said air-spaces being continued through the plate or disk, and having a second series of movable tubes or cylinders passing through them, on the top of which are placed the flanged rings for projecting the air into the flame, the said cylinders and flanges being raised and lowered by a screw and pinion, or any other well-known means. These said cylinders have ribs either on the outside or inside, (or both,) for dividing the air-spaces into equal parts; and the interior cylinders and flanged rings may be dispensed with when required.

A bracket for carrying the chimney, also raised and lowered by rack and pinion, encircles and may be fastened to the outer cylinder, so that both the bracket and cylinder may be raised and lowered together, if required, the said bracket having perforations for the admission of air to the outside of the flame.

The burners and disk are supported on columns, or otherwise, resting on a receptacle for containing a supply of oil, the commu-

nication therefrom to the burners being through small tubes, some of which may contain the racks for raising and lowering the said burners.

The receptacle above mentioned communicates with a receiver by means of a copper or other tube, having a cock at its lowest part for emptying it of its contents when required, which said tube may be carried under the lenses of a light-house, (when used for that purpose,) so that both the receiver and the air-tight reservoir, from which the receiver is supplied, may be placed outside the lenses.

The said receiver is placed at a convenient height for the plentiful supply of oil to the burners, and is self-regulated by means of a cock in the air-tight reservoir, so that, as soon as the oil in the receiver reaches the mouth of the cock, the flow ceases, there being no pressure of air on the top of the liquid in the reservoir, to which the oil is fed by means of a suitable cock placed thereon.

In order that my invention may be clearly understood, I will describe the same with reference to the accompanying drawings, in which—

Figure 1 is a section through the center of the lamp; Fig. 2, a plan of the said lamp; and Fig. 3, the general arrangement of the lamp, receiver, and reservoir.

a are the flanged rings for guiding the air to the flame, the said rings being supported on the cylinders *b*, which have ribs on one or both sides of them, for dividing the air-spaces *c* into equal parts, as shown in Fig. 1. *d* are the pinions, and *e* the racks for raising and lowering the wick-holders *f*. *g* is the perforated bracket for carrying the chimney *h*, which is raised and lowered by the pinion *i* and rack *k*. *l* is the receptacle communicating with the wick-spaces by the tubes *m*.

In Fig. 3, *n* is the lamp; *o*, the copper or other tube communicating with the receiver *p*, which is supplied, by means of the cock *q*, from the receiver *r*.

Having now described the nature and particulars of my said invention, what I claim is—

The herein-described apparatus for burn-

ing hydrocarbon oils, consisting of the wick-holder *f*, cylinders *b*, receptacle *l*, communicating-tubes *m*, the chimney-bracket *h*, and pinions and racks *d* and *e* and *i* and *k*, respectively, operating the wick-holders and chimney-bracket, the whole combined and arranged in the manner and for the purpose specified.

Done at London, England, this 27th day of July, 1868.

HENRY HARRISON DOTY.

Witnesses:

EDWARD THOMAS HUGHES,
123 *Chancery Lane, London.*

HENRY ROGEN,
123 *Chancery Lane, London.*

H. H. DOTY.

Lamp.

No. 109,303.

Patented Nov. 15, 1870.

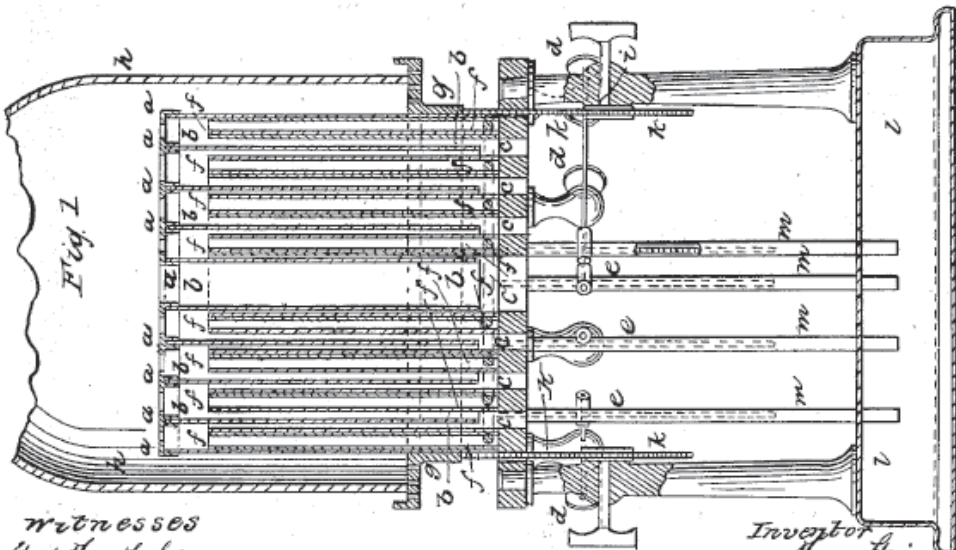
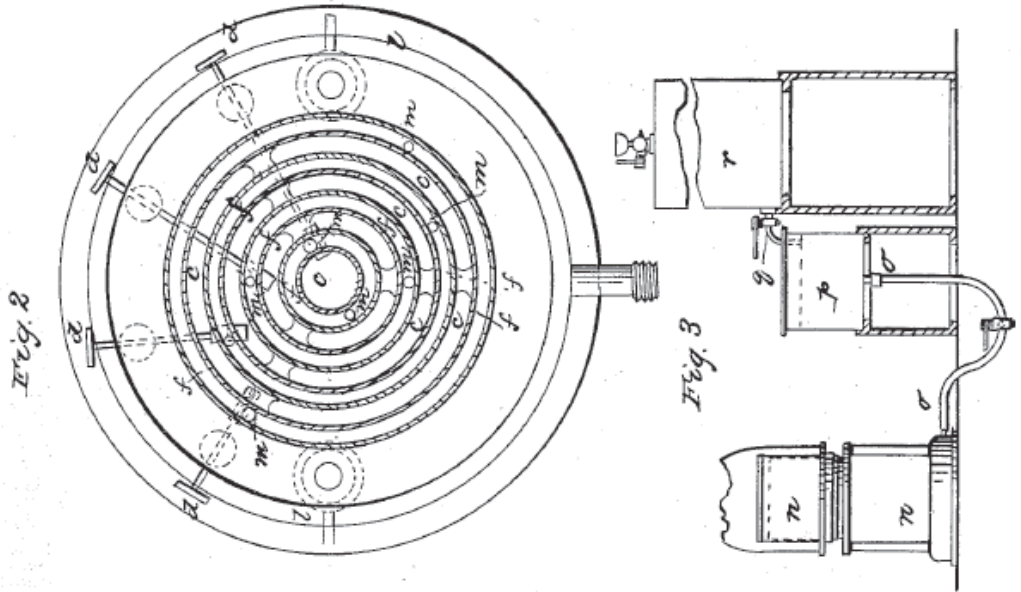

Witnesses
Wm. Thomas Hoyle
Henry Rogers

Inventor
Henry Hainan Doty
By his Attorney

The Doty Lamp was the first lamp truly capable of using kerosene (called paraffin in England) as a fuel. Joseph Funck used the Doty Lamp as a prototype when developing the kerosene lamps used in America. For more information see The Keeper's Log, Vol. 16, No. 4, *The Doty Dilemma*.



(Photo Courtesy Smithsonian Institution, National Museum of American History, Home and Community Life)
RWS2012-04602 Patent 109303 Paraffin Burner.

UNITED STATES PATENT OFFICE.

JOHN RICHARDSON WIGHAM, OF ALBANY HOUSE, MONKSTOWN, IRELAND.

IMPROVEMENT IN GAS-BURNERS.

Specification forming part of Letters Patent No. 148,909, dated March 24, 1874; application filed December 6, 1873.

To all whom it may concern:

Be it known that I, JOHN RICHARDSON WIGHAM, of Albany House, Monkstown, in the county of Dublin, Ireland, have invented an Improved Gas-Burner for Illuminating Light-Houses and other localities; and do hereby declare that the following description, taken in connection with the accompanying drawings hereinafter referred to, forms a full and exact specification of the same, wherein I have set forth the nature and principles of my said improvement, by which my invention may be distinguished from others of a similar class, together with such parts as I claim and desire to secure by Letters Patent—that is to say:

My invention relates to an improved construction of gas-burners, whereby I am enabled to dispense with the use of chimney-glasses, while a light superior to that of gas-burners heretofore employed is obtained therefrom; furthermore, by a device to be hereafter described I am enabled to reduce and increase the volume of light of such burners, at pleasure, without impairing the efficient action of the burner when used in connection with reflecting or refracting apparatus.

My improved gas-burner is shown on the accompanying drawings, of which Figure 1 shows an elevation, with part of the lower casing removed to show the internal structure. Figs. 2 and 3 show, respectively, a vertical section and a plan to an enlarged scale. Fig. 4 shows a perspective view of a half-ring of jets separated from the body of the burner, as will hereafter be described; and Fig. 5 shows an elevation of the burner reduced in size by removing the outer ring of jets, part of the lower casing being removed, as in Fig. 1, to show the internal structure.

The burner consists of a number of concentric circles of jets issuing from small tubes *a*, which project upward from the hollow rings *b*, surrounding a central sheaf of like tubes, which project upward from a cylindrical cavity, *c*. The latter cavity is connected by an upright pipe, *d*, provided with a stop-cock, to a gas-supply chamber, *e*, which forms the base of the burner. The central sheaf of jets, with their supply-cavity *c* and pipe *d*, forms the fixed or permanent part of the

burner, which may be employed when only a low illuminating power is required. When greater power is wanted, the rings *b* can be added successively, so as to extend the burner, their connection to or removal from it being effected by means which I will now describe. Each of the rings *b* is made in halves, one of such halves being shown in perspective at Fig. 4, and has a tubular stem, *f*, for conducting the supply of gas from the chamber *e* up to the cavity of the ring. This stem *f* is placed loosely in an annular trough formed in a socket-piece, *g*, and mercury or other liquid being poured into this trough, a hydraulic joint is at once formed, making a gas-tight connection of the stem-tube *f* to the socket *g*. The lower part of the socket *g* is made tapering, like the plug of a stop-cock, and fitted into a tapering seat formed in the supply-chamber *e*. A lateral hole, *h*, is bored into the plug of *g*, and the plug can be turned round in its seat by the hand applied to a knob, *k*, until the hole *h* of the plug is brought to face a hole bored through the conical seating into the chamber *e*. When the plug is so turned, the gas can flow through the plug and up the stem *f* to supply the half-ring *b*, and the jets therefrom. To regulate the gas-supply, or cut it off entirely, the socket *g* can be turned so as to diminish or entirely obstruct the passage *h* in the manner of a stop-cock. The half-rings *b*, when they are in place, rest by their ends on radial bars *l* projecting from the central part of the burner, and those ends have studs *m*, which enter holes in the radial bars, so as to steady the half-ring in its proper position. Although I prefer to make the rings *b* in halves, for facility of removal, yet it will be evident that entire removable rings may be used. The object of these movable rings of burners is to increase or diminish the light, according as the state of the atmosphere requires it.

By removing the outer rings of burners when a reduced amount of light is required, I prevent the obstruction of the lower rays of lights from the flame, which would be caused by the jets of the outer ring if they were left standing. If, instead of regulating the amount of light by the means described, this were effected by merely raising or lowering the height

of the flames from all the jets, the efficiency of the burners, more particularly as regards the local position of the flame relative to the reflecting or refracting apparatus employed in connection therewith, would be impaired.

The burner is surrounded by a conical casing or equalizer, *n*, which has the effect of equalizing, and to a certain extent concentrating, the supply of air passing upward to the several jets. When the burner is reduced in size by the removal of one or more of the rings *b*, the equalizer *n* is replaced by one of proportionally smaller size, as shown at Fig. 5, which represents the burner with its outer ring removed. Over the burner is suspended by a ring an oxidizer, *o*, being a cylinder or short tube or chimney, by which the products of combustion pass upward. It is made of somewhat smaller diameter than the burner, and the effect of this, combined with the conical form of the equalizer *n*, is to make the flame converge inward, and thereby to produce a very vivid illumination. When the burner is reduced in size, a smaller oxidizer is used, as shown in Fig. 5. As the flame in many cases extends to a considerable height above the

points of the jet-tubes *a*, I prefer to make the oxidizer *o* of talc, a material that is transparent, and at the same time little liable to injury by heat.

Having thus described the nature of my invention, and in what manner the same is to be performed, I claim—

1. The removable ring or rings *b* of jets, which can be added to or separated from the burner, as and for the purposes described.

2. In a burner having attachable and separable rings of jets, the stop-cock plug *g*, with an annular trough forming a hydraulic joint for the tubular stem *f*, as and for the purposes described.

In testimony whereof I have signed my name to this specification in the presence of two subscribing witnesses this 15th day of November, 1873.

JOHN RICHARDSON WIGHAM.

Witnesses:

JOHN DONOHUE,

Dublin, Householder.

PATRICK HAYES,

1 Anglesea St., Dublin.

J. R. WIGHAM.
Gas-Burners.

No. 148,909.

Patented March 24, 1874.

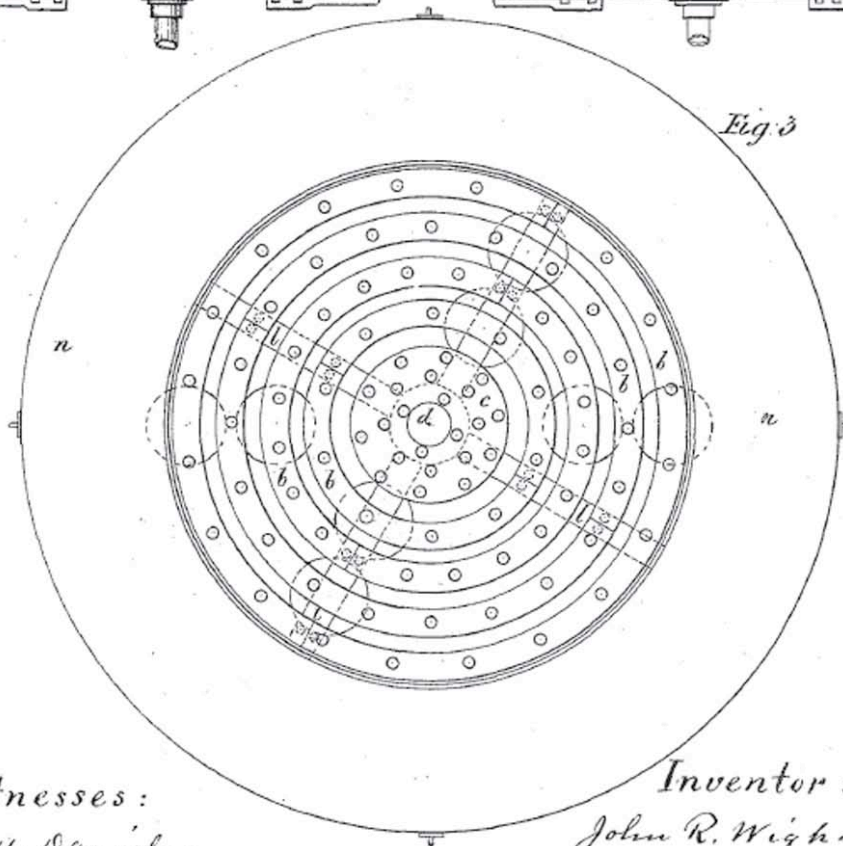
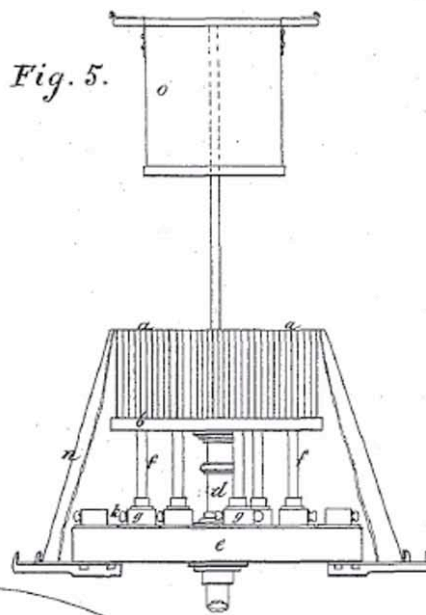
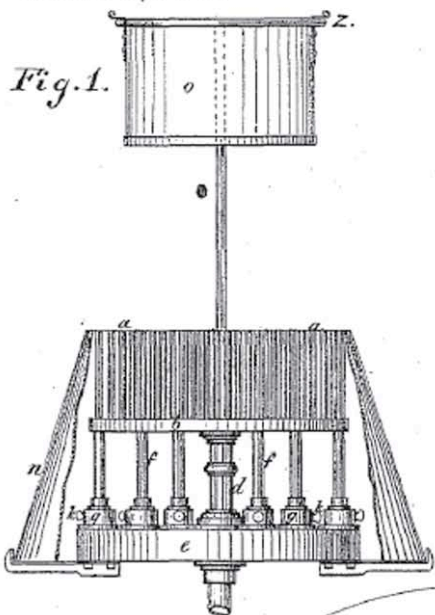

Witnesses:

H. C. Daniels
A. H. Davis

Inventor:

John R. Wigham
by *C. S. Whitman* atty.

J. R. WIGHAM.
Gas-Burners.

No. 148,909

Patented March 24, 1874.

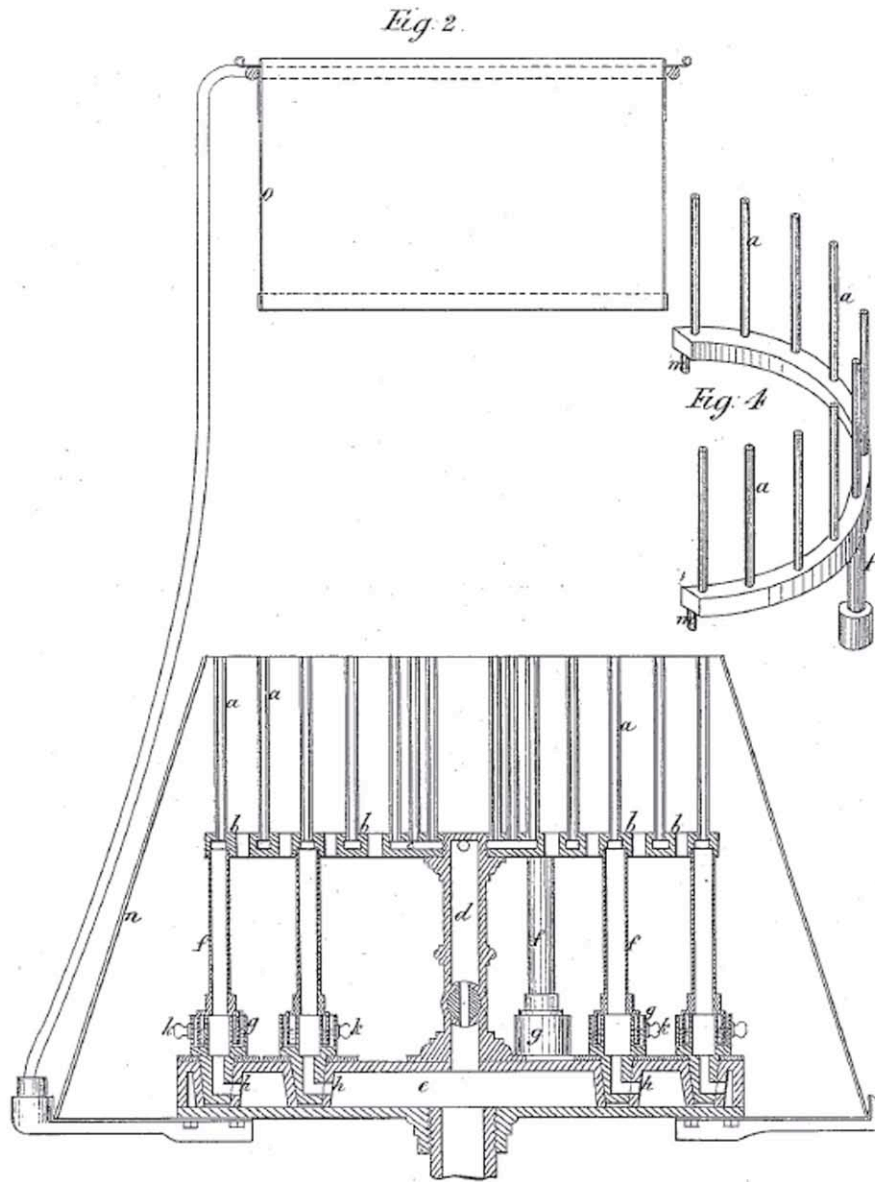

Witnesses:
H. A. Daniels
A. W. Davis

Inventor:
John R. Wigham
by Chas. S. Whitman
att'y

John Wigham's Gas Burners were never used in America. However, they were used extensively in the lighthouses of Ireland. For more information see: *The Keeper's Log*, Vol. 23, No. 2, *Brilliance and Prejudice – The John Wigham Story*.



(Photo Courtesy Chad Kaiser Collection)
Patent Model 148909 Wigham's Gas Burner - This model is not in the Smithsonian collection it is in private hands.

UNITED STATES PATENT OFFICE.

JOSEPH FUNCK, OF TOMPKINSVILLE, NEW YORK.

IMPROVEMENT IN BURNERS FOR LIGHT-HOUSE LAMPS.

Specification forming part of Letters Patent No. 177,825, dated May 23, 1876; application filed March 22, 1876.

To all whom it may concern:

Be it known that I, JOSEPH FUNCK, of Tompkinsville, Staten Island, in the county of Richmond and State of New York, have invented a new and useful Improvement in Argand Burners for Light-House Lamps, of which the following is a specification:

This improved Argand burner is designed primarily for Funck's hydraulic float-lamp for light-houses, but is not confined in its applicability to this particular lamp.

The present invention has for its objects a thin even flame of superior steadiness and intensity, and a simple and efficient burner, which is adapted to be readily taken apart, so as to be kept perfectly clean.

The first part of the invention relates to the wick-tube or oil-feeding devices; and consists in peculiar means for contracting the upper end of the wick, so as to lessen the charring thereof, and to improve its capillary action, and also to render the flame thinner and more even at the wick.

The second part of the invention relates to the arrangement of air-supply orifices; and consists in a perforated chimney-flange, by which air is admitted immediately within the chimney at its base, so as to furnish fresh air for the outside of the flame above the deflector-dome, and to reduce the degree of heat to which the chimney is subjected.

The third part of the invention relates to the construction of air-inlets and deflectors with reference to facility for thoroughly cleaning the parts, and the avoidance of unnecessary complication; and this part of the invention consists in a deflector made removable from within the upper air-jacket, and a separable cap or guard at the bottom of the burner for admitting air to the interior of the flame, as hereinafter more fully set forth.

Figure 1 is an elevation of this improved burner. Fig. 2 is a vertical longitudinal section on the line 2 2, Fig. 1. Fig. 3 is a horizontal section through the upper air-inlets on the line 3 3, Fig. 1. Fig. 4 is a horizontal section through the lower air-inlets on the line 4 4, Fig. 1.

Like letters of reference indicate corresponding parts in the several figures.

T represents the annular wick-tube; E e^1

e^2 e^3 , the parts of an ordinary wick-elevator; W, the wick; O, the lateral oil-inlet; S, a safety-tube leading from an orifice near the upper end of the outer wall of the wick-tube to prevent overflow; B, the flame-expanding button; D, the external "deflector"; J, the air-jacket for the upper end of the wick-tube; C, the cap for the lower end of the burner; and A a pivotal supporting-arm.

In constructing a wick-tube for a given size of wick, capacity must be provided not only for the wick itself, but also for the carrying-ring e^3 of the wick-elevator, with some additional margin to facilitate introducing the wick. This renders the upper end of the wick quite loose in an ordinary tube, permitting it to swell and fray, and, consequently, to burn freely itself, whereas the object is to confine the combustion as exclusively as possible to the exuded oil. To remedy this defect the outer wall of the wick-tube is made shorter than the inner wall, and the space thus exposed at the upper end of the tube is occupied by a contracting-collar, e^1 , as clearly shown in Fig. 2. The construction of the tube proper, besides its primary effect, serves to afford additional facility for readily renewing the wick. The wick-contractor having been removed, the attaching-jaws of the elevated carrying-ring e^3 spring apart above the low top of the outer wall of the wick-tube, and release the old wick. The new wick is placed around the projecting upper end of the inner wall of the tube, and within the jaws of the carrying-ring, and the wick is then drawn in by lowering the ring. The contracting-collar is formed at the upper end of a sleeve, S^1 , which slides tightly onto the wick-tube. The jacket J is attached to this sleeve, and is removable therewith.

The main air-inlets a^1 a^2 of the improved burner consist of a sufficient number of moderately large perforations, in circumferential rows, formed in the otherwise imperforate outer walls of the jacket J and cap C, as shown in all the figures.

The inlets a^3 admit air to the interior of the flame through the center of the wick-tube. Air admitted at the inlets a^1 strikes the outside of the flame immediately above the wick, beneath the dome d of the deflector, and a

small portion of that which reaches this point escapes unconsumed through orifices in the dome.

To provide a more ample and fresh supply of oxygen to the exterior of the flame above the dome of the deflector, a perforated chimney-flange, *f*, has been provided in this burner. The perforations extend entirely around the dome, and close thereto. Air is thus admitted immediately within the base of the chimney from the main inlets *a*¹ direct, and serves to cool the chimney, while it renders the combustion much more perfect and materially increases the brilliancy of the flame.

The deflector *D*, in addition to its ordinary perforated dome and the chimney-flange *f*, which is formed thereon, has, below the latter, an apron or drop-partition, *p*, extending down below the air-inlets *a*¹, to divide and equalize the entering air, and to cause the main portion to pass in contact with the sleeve *s*¹ throughout its length, so as to absorb heat from the wick-tube. The jacket *J* is formed with a shoulder, *s*², to form a seat for the flange *f*, and the deflector is thus supported within the jacket, so as to be readily removable, to facilitate cleaning it, and to give convenient access to the interior of the jacket for the same purpose.

The walls of the cap *C* are double, a concentric inner wall, *i*, of perforated sheet metal, having minute orifices, being employed to divide up and regulate the force of the entering air. The cap is removable from the wick-tube, being attached by a screw-collar, *c*², embracing a threaded neck at the lower end of the tube. To render the cap separable, the screw-collar *c*² is extended, and provided externally with a collar and threaded portion within the cap. The latter receives another screw-collar, *c*³, soldered within the upper end of the inner annular wall *i*. The outer wall is soldered to the main collar *c*². The bottom disk *b* of the cap is imperforate, and is attached to the inner wall *i*, and finished with a milled edge. By turning this the outer collar *c*³ is unscrewed, and the bottom disk and inner wall are released. When they are in position the bottom disk fits tightly against the lower edge of the outer wall. The ordinary extension-tube *e*¹, to accommodate the rack *e*² of the wick-elevator, is inclosed within the cap *C*, as in other burners.

The burner is supported within its reflector by the arm *A*, and is supplied with oil through a pipe, *O*. An ordinary chimney upon the chimney-flange *f* completes the outfit.

When a new wick is to be introduced the jacket *J* and its contents can be removed together, while for trimming the wick the deflector *D* alone need be removed besides the chimney.

The style of the air-inlets *a*¹ *a*² renders them free from liability to become clogged, and facilitates cleaning and polishing the outer sur-

faces of the burner, and the construction of the jacket *J* and cap *C*, as above described, gives easy access to the inclosed parts which require cleaning.

I do not claim, broadly, any device for holding the wick of an Argand burner around the upper end of a relatively extended inner wall or central draft-tube. I am aware of such a burner having a "wick-assembling shell," in combination with two or more short wick-tubes, conducting separate wicks, which are assembled around the inner wall or draft-tube by said shell. This shell is a fixture, and the wicks are necessarily inserted at the bottom of the burner. This device could not, therefore, be used in a lamp of the description to which this invention relates. My wick-contractor is movable, and is applicable exclusively to an annular wick-tube, which receives the wick at top. After the wick is inserted the contractor is applied, and forms an extension of the outer annular wall.

I am also aware of the common Argand burner, in which a rotary wick-carrying tube is employed, and the upper part of the outer wall of the annular wick-tube is omitted. I do not claim any such device. Neither do I claim, broadly, a removable deflector, as I am aware that the simple dome employed in some Argand burners has been made removable.

The following is claimed as new and of this invention, namely:

1. In combination with an annular wick-tube, adapted to receive the wick at top, and constructed with a fixed outer wall, terminating a short distance below the upper extremity of the inner wall, the wick-contractor *c*¹, adapted to be applied after the wick is inserted, and to form a contracted extension of the outer wall of the wick-tube independent of the wick-elevator, substantially as herein shown and described.

2. The combination of the wick-contractor *c*¹, formed at the end of the sleeve *s*¹, and the jacket *J*, attached to the lower end of said sleeve, the same being adapted to be applied to and removed from the wick-tube together, substantially as set forth.

3. The perforated chimney-flange *f*, in combination with the jacket *J*, drop portion *p*, and dome *d*, for the purposes set forth.

4. The removable deflector *D*, consisting of the dome *d*, chimney-flange *f*, and drop-partition *p*, in combination with the jacket *J*, having the shoulder *s*², to support the same in position, substantially as shown and described.

5. The removable and separable cap *C*, having concentric annular walls, a bottom disk, *b*, and screw-collars *c*² *c*³, combined substantially as herein described, for the purposes set forth.

JOSEPH FUNCK.

Witnesses:

JAS. L. EWING,
ABNER C. THOMAS.

J. FUNCK.

BURNERS FOR LIGHT-HOUSE LAMPS.

No. 177,825.

Patented May 23, 1876.

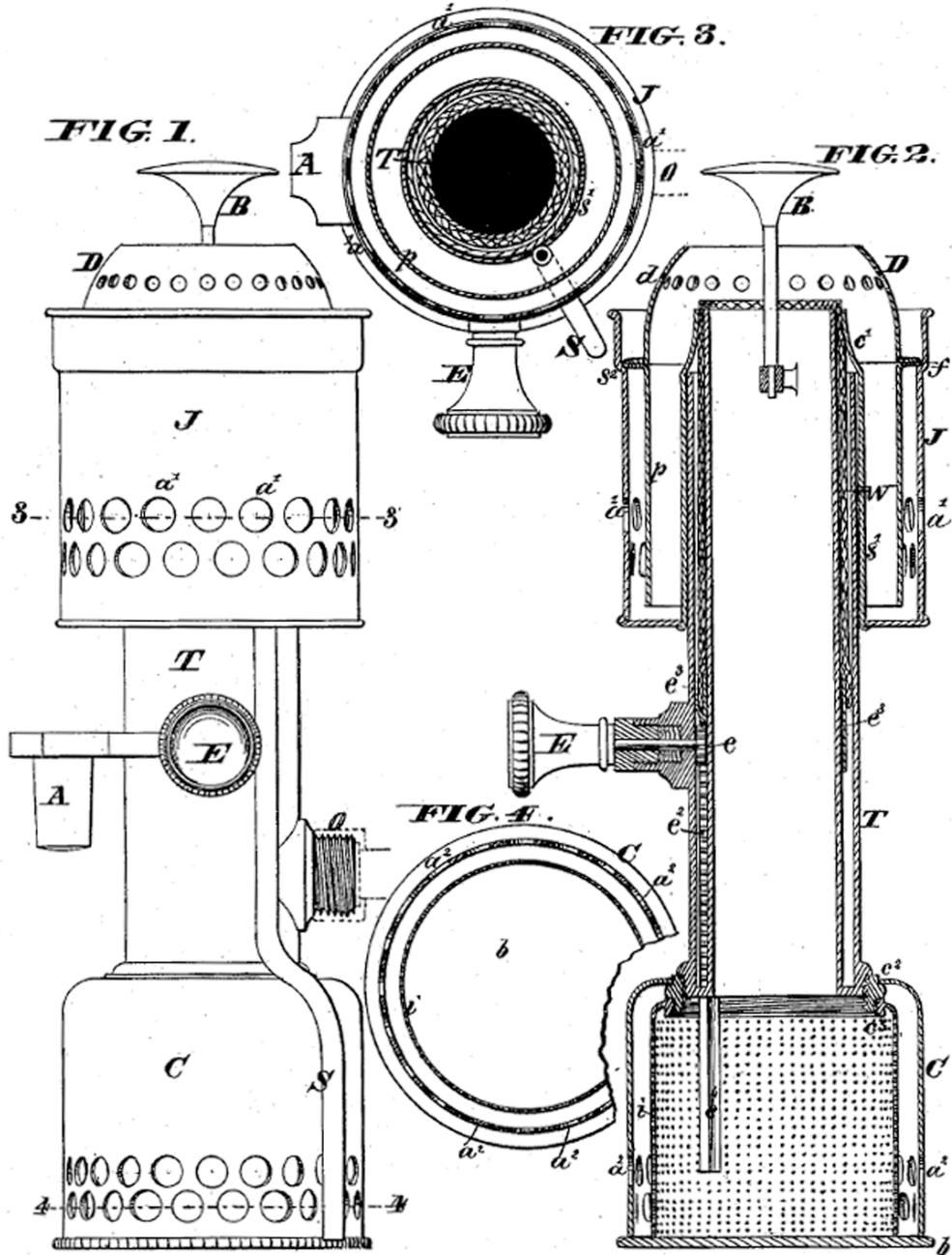

WITNESSES
Chas. Hoock
H. Salt

INVENTOR
Joseph Funck
By Knight & Co. Attorneys

Joseph Funck was the foreman of the 3rd District Lighthouse Depot. He designed many lighthouse lamps and his designs became the standard American lamps for lighthouses. For more information see *The Keeper's Log*, Vol.19, No. 1, *From Braziers and Bougies to Xenon*.

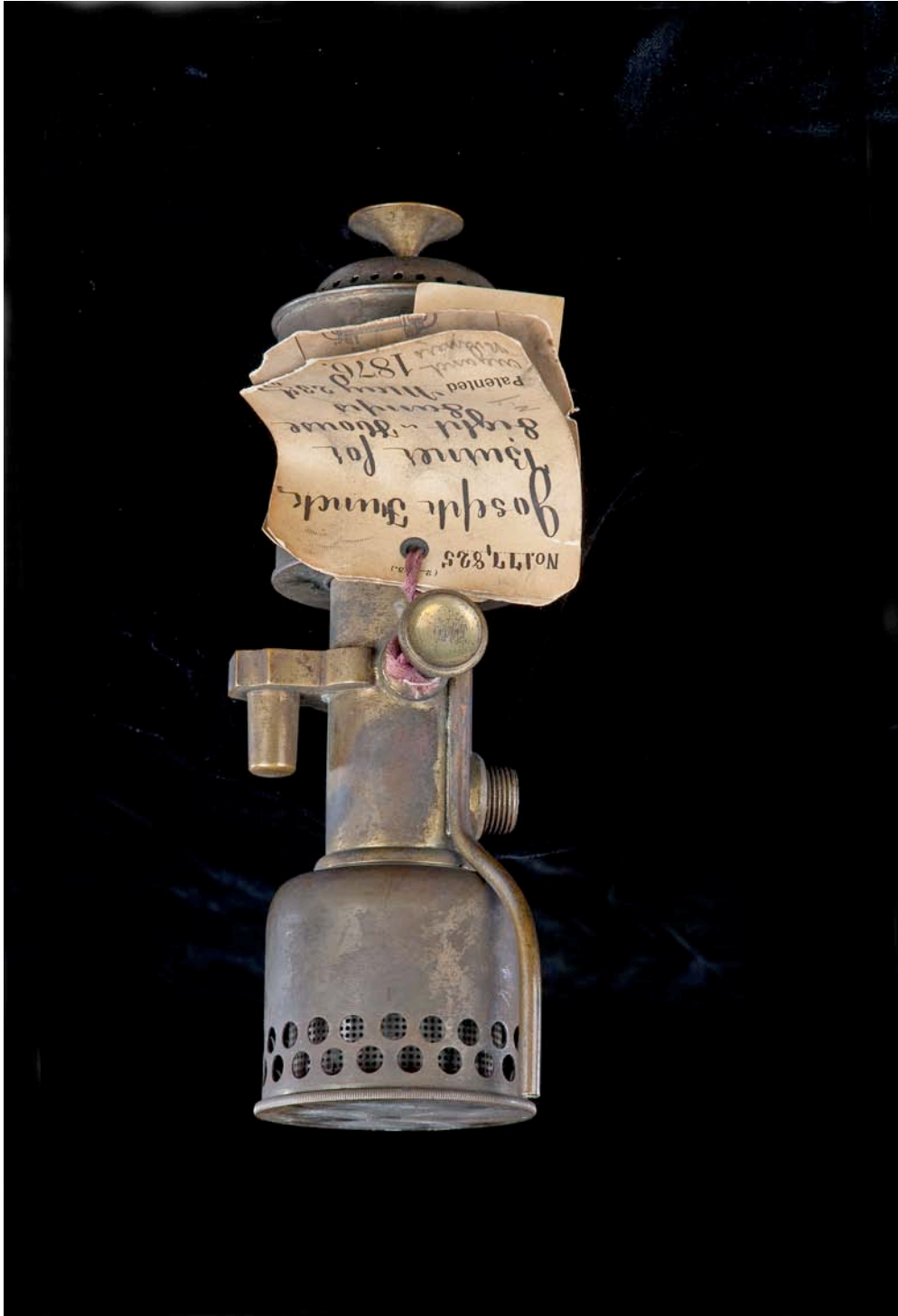

(Photo Courtesy Smithsonian Institution, National Museum of American History, Home and Community Life)
RWS2012-04604 Patent 177825 Lighthouse Lamp Burner.

UNITED STATES PATENT OFFICE.

RICHARD PINTSCH, OF BERLIN, PRUSSIA.

IMPROVEMENT IN FLOATING SIGNAL-LIGHTS.

Specification forming part of Letters Patent No. **190,979**, dated May 22, 1877; application filed January 23, 1877.

To all whom it may concern:

Be it known that I, RICHARD PINTSCH, of Berlin, Prussia, engineer, have invented an Improvement in Floating Lights; and do hereby declare that the following description, taken in connection with the accompanying drawings, hereinafter referred to, forms a full and exact specification of the same, wherein I have set forth the nature and principles of my said improvement, by which my invention may be distinguished from others of a similar class, together with such parts as I claim and desire to secure by Letters Patent—that is to say:

This invention relates more particularly to improved means and apparatus whereby buoys moored off the sea-coast, or in other waterways, are rendered available as floating lights, for indicating their position at night or in dark weather, such apparatus being also available for use in light-ships, or for floating lights generally.

The invention consists, mainly, in utilizing such buoys as recipients for illuminating-gas under pressure, which is supplied thereto at intervals from a reservoir on board a boat by means of flexible hose temporarily attached to an inlet-pipe, with stop-cock on the buoy. A vertical tube leads from the latter to a lantern raised some height above the water-level, in which are one or more gas-burners, supplied with gas from the interior of the buoy, a regulator being provided at any convenient point of the supply-pipe for reducing the pressure of the gas, as it passes from the buoy, to the ordinary pressure of illuminating-gas before it issues from the burner or burners.

The construction and the arrangement of such apparatus, which I prefer to employ for the purposes of my invention, are shown on the accompanying drawing, in which—

Figure 1 shows an elevation of the buoy and lantern. Figs. 2 and 3 show an enlarged vertical section, respectively, of the lantern and of the casing below. Figs. 4 to 6 show cross-sections, taken respectively on lines *gh*, *ab*, and *c d*, Figs. 2 and 3. Fig. 7 shows a longitudinal section, and Fig. 8 a cross-section at X X, of a device for connecting the charging-hose to the inlet-pipe of the buoy, for filling the latter with gas.

The recipient or buoy B, Fig. 1, is construct-

ed of strong sheet metal, of cylindrical or other suitable form, capable of withstanding considerable internal pressure. It is secured at its lower end to any suitable moorings, in the usual manner, and has fixed on its upper end a tube, D, strengthened by stays, and carrying at its upper end a casing, A, surmounted by a lantern, C.

The tube D serves both to convey the supply of gas under pressure from the charging-reservoir into the buoy, and to conduct the gas from the buoy to the burner *m*² in the lantern. For the first-named purpose the tube has at its upper end, within the casing A, a side branch, *f*, the communication between which and the tube is closed by a screw-valve, F. The branch *f* has a coned recess at its end, as shown, for receiving the coned end *v* of the nozzle V, Fig. 7, the branch V¹ of which is attached to a flexible pipe leading to the charging-reservoir.

For charging the buoy, the boat, with the reservoir for compressed gas, is brought close alongside, and a sliding door, A', in the casing being opened, the end *v* of the nozzle V is placed inside the socket of the branch *f*, and is forced gas-tight therein by means of a screw, *v'*, carried by a sleeve, V², connected to the nozzle, and having a claw, embracing a collar on the branch *f*, as shown. The nozzle having been securely fixed, the screw-valve F is opened, and the compressed gas is allowed to flow from the reservoir into the buoy until the pressure-gage M, fixed on another branch pipe, *f*², indicates that the gas in the buoy has attained the required degree of compression. The valve F is then again closed and the supply-hose detached. The compressed gas now passes from the buoy, through the passage *f*² and pipe *m*, into the regulator R, which is, by preference, of the same construction as that described in my previous patent of 4th May, 1875, No. 162,946, in which the gas flowing from the pipe *m* passes, through the dust-collector *r*³ and valve *r*⁶, into the chamber R, in which is a lever *r*⁵, connected to the valve *r*⁶, and also to an impermeable flexible diaphragm, *r*², by a rod, *r*⁴, so that the pressure of the gas entering the chamber tends to raise the diaphragm, and so to close the inlet-valve more or less.

A spring, r^2 , is connected to and acts upon the lever r^3 , in such a manner as to hold the valve open in the exact position for admitting sufficient gas to maintain the required pressure in the regulator. A second spring, r^4 , is also connected to the lever r^3 and to the stem of the valve, so that when the lantern is made to assume an inclined or nearly horizontal position by the action of the waves, this spring will replace the action of gravity in pulling the valve open after it has been closed through excess of pressure.

From the regulator the gas passes, through the passage r^{10} and cock r^{11} , to the pipe m^1 , whence it passes to the burner m^2 . The cock r^{11} can be turned from outside the casing to adjust the flame of the burner.

The lantern consists of two concentric glass cylinders, I J, fitting with their upper and lower ends air-tight against caoutchouc packing $k k$ in undercut grooves formed in metal rings G H, of which H is fixed to the casing A, while G is tied down to H by means of tie-bolts X. The top of the lantern is closed by a cover, T, hinged to the ring G at j , and fitting with beveled rims t , in an air-tight manner, against corresponding rims on G, and secured by a catch, t' . The cover has, first, a chimney, S, into which the products of combustion from the burner are led through the chimney y , which is, by preference, of oval transverse section, as shown at Fig. 4, and is supported by the upper reflector y' . The chimney S is closed by a cap, s , at top, the gases being made to escape through the conical piece s^1 and holes o , protected by the wind-guard $s^2 s^3$, and also by a projecting rim, s^4 , against the action of the wind, and also against the ingress of water-spray. The air for supporting combustion enters through the wind-guard l^2 , and, passing through holes Z into the annular space between the two glass cylinders I J, descends therein, and issues through holes Z^1 in the ring H into the space below the reflector K, whence it passes, through a number of small holes, i , in the reflector, into the interior of the lantern. Any water-spray that may possibly find its way through the wind-guard will flow off through the holes Z Z^1 , and through other holes, Z^2 , in the bottom of the casing A, without interfering with the action of the lamp.

It will be readily understood that the above-described arrangement of a reservoir for compressed illuminating-gas, in combination with the regulator and lantern, may also be used with advantage on board light-ships without further invention.

Having thus described the nature of this invention, and in what manner the same is to be performed, I claim—

1. The combination of a buoy or floating recipient for compressed illuminating-gas with a lamp and a regulating apparatus, for reducing the pressure of the gas as it passes from the recipient to the burner, substantially as herein described.

2. An illuminating apparatus for floating lights, consisting of a recipient for compressed illuminating-gas, with charging-inlet closed by a valve, combined with a regulator and gas-burner, arranged and operating substantially as herein described.

3. In a lantern for floating lights, the combination of the two concentric cylinders which surround the burner with the wind-guard l^2 and perforated reflector K, substantially as and for the purpose specified.

4. In lanterns for floating lights, the concentric glass cylinders I J, secured with caoutchouc packing k in metal rings G H, having holes Z for the inlet of air, in combination with the hinged cover T and chimney S, arranged and operating substantially as herein described.

5. In illuminating apparatus for floating lights, the lantern H G I J, with burner m^2 , in combination with the closed casing A, containing the regulator R and charging-inlet F, communicating with the tube D, substantially as herein described.

6. In a lantern for floating lights, the combination of chimney S, and its conical piece and cap, with the wind-guard and the burner and its chimney, substantially as and for the purpose specified.

In witness whereof I have hereunto signed my name in the presence of two subscribing witnesses.

RICHARD PINTSCH.

Witnesses:

BERTHOLD ROJ,
ROBERT GOTTHEIL.

R. PINTSCH.
FLOATING SIGNAL-LIGHT.

No. 190,979.

Patented May 22, 1877.

Fig. 1.

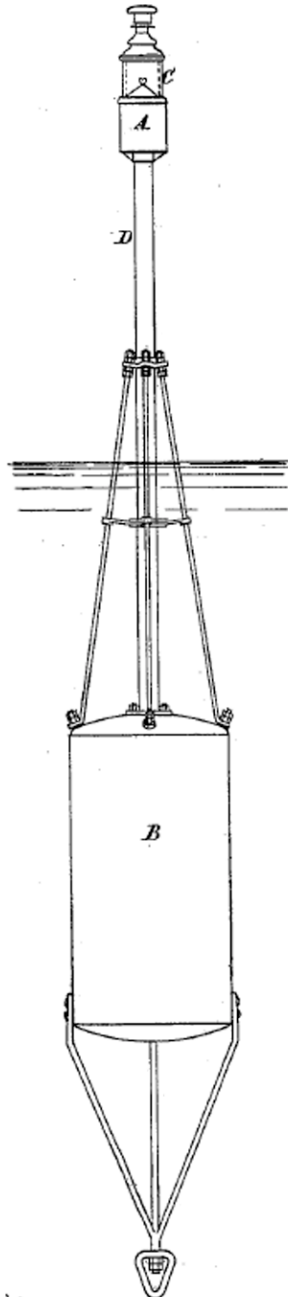

Fig. 4.

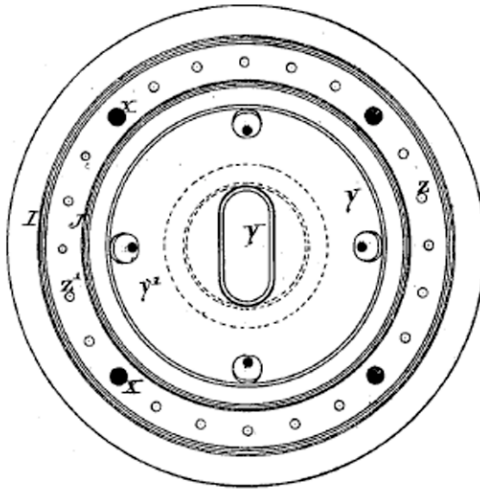

Fig. 5.

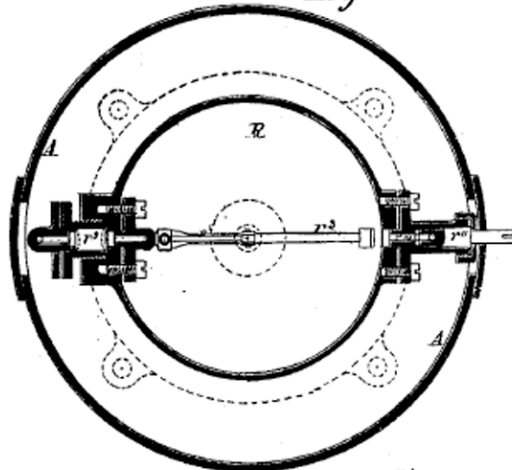
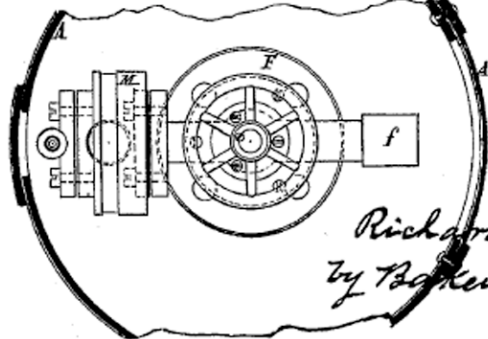

Fig. 6.



Witnesses
R. W. von Schaed,
James & Kay.

Inventor.

Richard Pintsch
by B. Kemell & Herr
Altje

R. PINTSCH.
FLOATING SIGNAL-LIGHT.

No. 190,979.

Patented May 22, 1877.

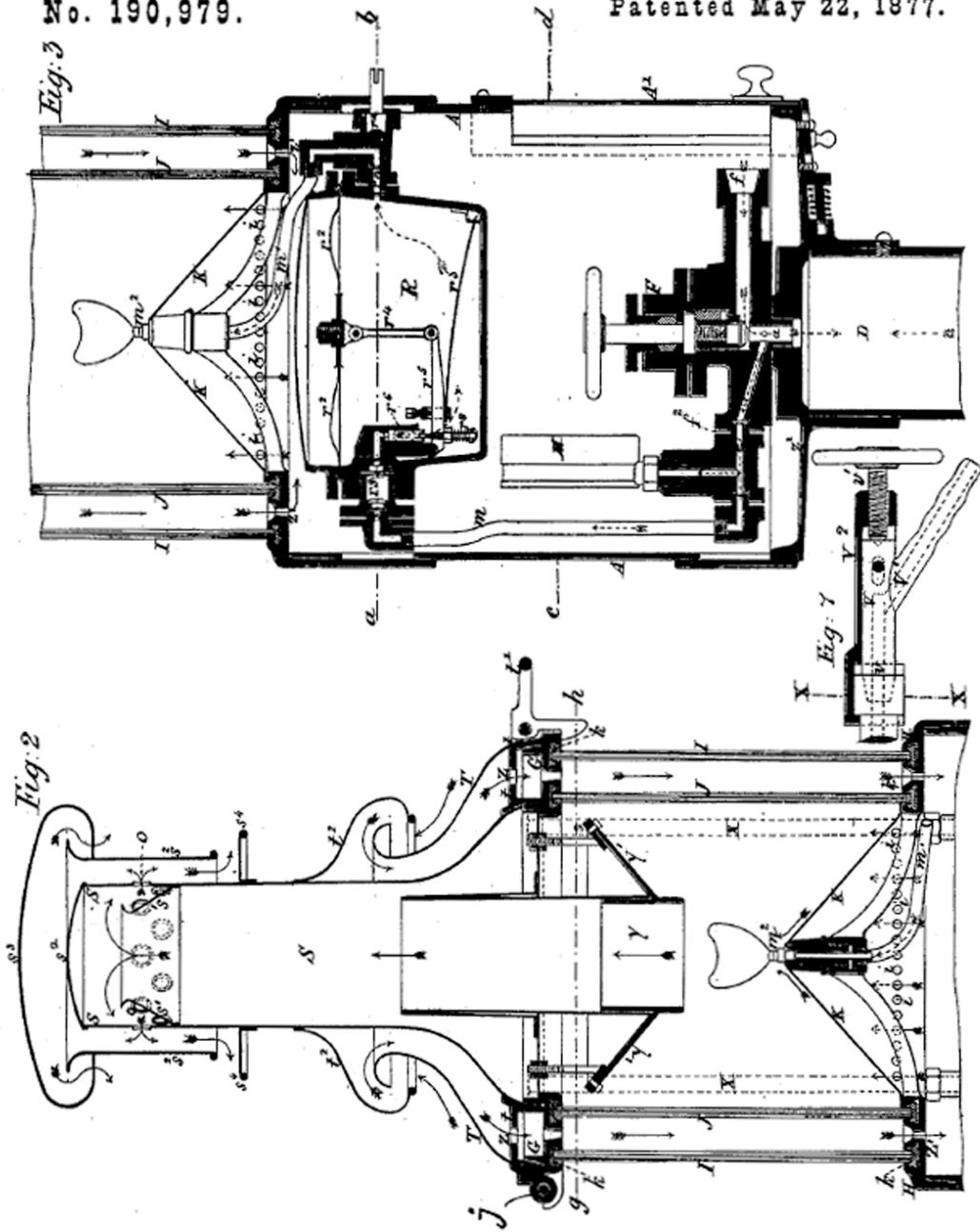

Witnesses.

R. W. Wainwright
James L. Gray

Inventor.

Richard Pintsch
by Bakewell & Kerr
Attys.

Fig. 8



Pintsch Buoys were used all over the world. Julius Pintsch the founder of the company in Germany designed the first lighted buoys. His son Richard designed this Lighted Buoy.



(Photo Courtesy Smithsonian Institution, National Museum of American History, Home and Community Life)
RWS2012-04605 Patent 190979 Floating Signal Light.

UNITED STATES PATENT OFFICE.

JOSEPH FORREST, OF OAKVILLE, MARYLAND.

IMPROVEMENT IN SELF-LIGHTING LAMPS FOR LIGHT-HOUSES.

Specification forming part of Letters Patent No. **204,806**, dated June 11, 1878; application filed May 14, 1878.

To all whom it may concern:

Be it known that I, JOSEPH FORREST, of Oakville, in the county of St. Mary's and State of Maryland, have invented certain new and useful Improvements in Self-Lighting and Self-Extinguishing Revolving Lamps for Light-Houses, Buoys, Wharves, &c.; and I do hereby declare that the following is a full, clear, and exact description thereof, which will enable others skilled in the art to which it appertains to make and use the same, reference being had to the accompanying drawings, and to letters of reference marked thereon, which form a part of this specification, in which—

Figure 1 represents a side elevation of the lamp-reservoir, lamps, and actuating devices for revolving the lamp, with the lantern-frame and the lamp-chimneys shown in dotted lines. Fig. 2 represents a section taken vertically through the reservoir and spindle on which the lamps revolve, and also through the stop-plate and devices for revolving the lamps on the stop device being released, to show details of construction, the oil-reservoir being broken off. Fig. 3 represents a partial vertical section taken through one of the lamp-tops, the cone or burner being thrown back or raised, and, like the lighting device, shown in elevation. Fig. 4 represents a plan of the lamp-top, with its cone or burner removed to illustrate the details of the extinguishing device. Fig. 5 represents a plan of the clock-movement, releasing device, and stop device through which an intermittent revolving motion is imparted to the lamps. Fig. 6 represents a detached sectional view of the lamp-lighting device, taken longitudinally through its center to show its details and construction. Figs. 7 and 8 represent a side elevation and plan of the cam devices for releasing the plunger of the lighting devices and for operating the lamp-extinguishers.

My invention relates to a self-lighting lamp for use on buoys, piers, wharves, light-houses, and other places, so as to dispense with the daily attentions of an attendant.

My invention consists, first, in combining a series of lamps with a time-movement, whereby it is made to perform a partial revolution at stated intervals, and for purposes hereinafter to be described; second, in combining,

with each of a series of lamps having an intermittent revolving motion, a self-lighting device put in action by said motion and suitable devices for that purpose; third, in combining, with each of a series of lamps having an intermittent revolving motion, an extinguishing device put in action by said motion and a suitable device for that purpose.

In the drawing, A represents an open frame or lantern, of suitable construction, in which the lamps are mounted, and which may also be of any suitable shape, such as round or polygonal, and the sides of which are covered in any suitable way with panes of glass to exclude the wind. On the bottom of this lantern-frame is secured a short stud, B, on which is formed or otherwise secured a stationary ratchet-disk, C, provided with a series of teeth or notches, *a*.

Standard B is provided with a tubular opening through its center for the reception of a spindle or stem, D, and which rests in a step, *b*, formed in the lantern-bottom, or, if desired, it may be formed in the lower part of the standard B.

A circular groove, *c*, is formed at the lower end of spindle D around its periphery, for the reception of a pin, *d*, which passes through the stud B and lies in the groove *c* of the spindle D, and thereby, while holding the latter in place, leaves it free to turn or revolve in its bearing in the stud, for a purpose to be hereinafter described.

On spindle D, immediately above stud B and its ratchet-disk C, is rigidly secured, in any suitable and known way, an arm, E, to the outer end of which is pivoted a drop-pawl, *e*, and which is intended to engage with the teeth *a* of the stationary ratchet-disk C, for a purpose to be hereinafter described.

In the drawings, arm E is represented as being formed on a collar, *f*, and the latter mounted on and secured to the spindle by a set-screw.

Immediately above the collar *f* and arm E is arranged a strong spiral spring, F, the inner end of which is secured to the spindle D, and the outer one to a wrist pin or stud, *g*, secured to the under side of the toothed release-disk G, and which latter is also mounted upon and rigidly secured to spindle D. The hub

of disk G is raised above its face in cone form, and on its upper side is provided with one or more notches for the reception of one or more lugs or detents, *i*, formed on the lower end of the tubular portion *h* of the oil-reservoir, and which thereby connects the oil-reservoir and lamps with the release mechanism and spindle.

On the stem or spindle D is mounted the oil-reservoir H, and which for this purpose has a tube, *h*, running through its center, and secured, respectively at its upper and lower end, to the top and bottom of the reservoir, with an air and water tight joint. Through this tube the spindle passes, and is made to fit it snugly, but without binding. Into the top of this reservoir H is fitted in the usual manner the lamp-tops J, and which may be of any suitable construction, whether for burning with or without a chimney; but a chimney-lamp is preferred. To each of these lamp-tops (see Figs. 3, 4, and 6) is secured a lighting apparatus, J, of any approved or suitable construction, in such manner that the open end is within convenient distance of the wick, in order to light it when the match-light is struck. For this purpose the upper end of the lighter J passes into the lamp-shell underneath the cone or burner. A lighter suitable for the purpose is shown in section in Fig. 6, in which J represents an elongated cylindrical metal case, soldered or otherwise made fast to the lamp-top, as shown in Fig. 3. Into the lower end of this case is arranged a plunger, *o*, carrying a stem, *o'*, and knob or button *o''*. Around stem *o'*, between the plunger and end of the case, is arranged a spiral spring, *p'*, and which imparts motion to the plunger when the latter is released from the pivoted lock-stop *q*. Lock-stop *q* consists of a bent lever, pivoted to the side of the case J, and having a bent end, *m*, which is made to protrude into the interior of the case J through an opening formed in its side for that purpose.

By this construction, on drawing the plunger *o* down by the stem *o'* below the bent end *m* of the lever *q*, and then pressing it in above the plunger, the latter will be held in that position until released by pressing the lever inward toward the casing. In this position the spring *p'* is held in a compressed position, so that when the plunger is released from lock-stop *q* the plunger *o* is forced rapidly forward, pushing before it the match *n*, and igniting it by causing its end which carries the fulminate to chafe against the roughened surfaces *o''* formed on the inside of the upper end of the casing. That the match may be easily inserted, one side of the upper end of the casing J is slotted, and into it is fitted an internally-roughened spring-bar, *p*, the lower end of which is flexibly secured, as by a spring-plate, to the casing J at the lower end of the notch or slot. (See Fig. 6.)

K represents a spring, the lower end of which is secured to casing J, and the upper attached in any suitable way to the roughened

bar *p*. This spring serves to press the bar *p* inward against the match to yield the necessary friction for its ignition, and at the same time yields to allow bar *p* to be drawn back far enough to yield a free passage for the match on being inserted to prepare the lighter for its work, as shown in Fig. 6.

r represents an extinguisher, consisting of a short section of a tube, which is made to surround the wick-tube, and is about the same length as that portion of the wick-tube which stands above the air-screen *s*. (See Fig. 3.) To the side of this tube is secured a bent wire rod or lever, *t*, in which is formed a short coil, through which the straight end of a hooked or bent stud, *u*, passes, the lower end of which is secured to the lamp-top. This pin forms the pivot on which the lever *t* turns. The outer end of this lever *t* then passes down through the top plate of the shell of the lamp-top, and is then again bent downward and outward, as shown in Fig. 3, to form a lever, *r'*, by which to raise the tube *r* and extinguish the flame.

P, Figs. 1, 7, and 8, represents a standard rigidly secured to the frame of the apparatus, which carries at its upper end two cam-rods, Q R.

Cam-rod Q is intended to operate on the lock-lever *q* of the lighting apparatus, forcing its upper end in, and thereby releasing the plunger *o*, which, through the action of the spring *p'*, is then driven forward, and, in so doing, ignites the match, and the latter the lamp. Cam-rod R is intended to act on the lower end of the lever *r'*, the other end, *t*, of which carries the extinguisher *r*.

Various modes of raising the extinguisher may be used, as by a rigid arm moving over a stationary cam-face; or, instead of a tubular extinguisher, a hinged cap-extinguisher may be used, and operated in the same way as that illustrated for the tubular one.

In Fig. 5 is illustrated the release mechanism. S represents a time-movement, which may either be an eight-day or two-week movement.

Upon the spindle which usually carries the hour-hand is secured an eccentric, *v*, and which is arranged between two arms, *w w*, of the escapement U, which is pivoted to the frame of the clock-movement. At the side of the clock-movement thus constructed is arranged the standard B and spindle D in such manner that the teeth *x* of the release-disk G will project between the detents *y* of the escapement-lever U, as shown in Fig. 5.

Thus arranged the disk G will be provided with teeth according to the number of lamps to be used in the apparatus. As a rule, I prefer to provide it with seven lamp-burners, one for each night of the week. When thus constructed the disk G will carry fourteen teeth, and the ratchet-disk C the same number, two teeth for each twenty-four hours, for the reason that the eccentric *v* of the clock-spindle performs one revolution every twelve hours,

and therefore releases a tooth, x , of the disk every twelve hours, whereupon the spring F, acting on disk G, causes it to perform a part of a revolution equal to one-fourteenth of the whole, carrying with it, through the teeth $i i$ on the lower end of the tube h of the oil-reservoir, the latter and lamps.

Now, let us suppose that the lamps are so set that the release of disk G shall take place at six o'clock in the evening and six o'clock in the morning; then the first tooth released would allow the lamps to be forced around just sufficiently far to cause the cam-rod Q to compress lever q of the lighting apparatus J, thereby releasing plunger o and match n , igniting the latter, and, in so doing, that lamp. Then, at the end of the next twelve hours, the next tooth of wheel G would be released, thereby causing the lamps to perform another one-fourteenth of a revolution, or just half the distance between the lamps, thereby bringing the lower end of the lever $r' t$ in contact with the cam-rod R, and by this means raising the short tube r and extinguishing the lamp. Here the extinguisher is held until the next tooth is released and the next lamp is brought into position and lighted, and so on until the end of the week, when all have been lighted and extinguished, after which the attendant comes and removes the lamps and reservoir, and replaces it with another, or else refills and trims, and places new matches in each lighter, and then replaces it for another week's work.

W represents the handle for removing the

lamps from the lantern, the top of which may be made removable for that purpose, suitable fastenings being used for keeping it in its position. Each lamp, if desired, may be provided with a separate oil-reservoir. Spring F, which moves the lamps, is wound up weekly by applying a suitable key to the top of spindle D and turning it in the proper direction, the ratchet C, arm E, and pawl e holding it in place when wound.

Having described my invention, what I claim as new, and desire to secure by Letters Patent, is—

1. The combination of one or more lamps and intermediate mechanism, substantially as described, with a time-movement, whereby an intermittent revolving motion at regulated intervals apart is imparted to the lamp, for the purposes set forth.

2. The combination, with each of a series of lamps having an intermittent revolving motion, of an extinguishing device, substantially as set forth.

3. The combination, with each of a series of lamps having an intermittent revolving motion, of a self-lighting device, substantially as described.

In testimony that I claim the foregoing as my own I affix my signature in presence of two witnesses.

JOSEPH FORREST.

Witnesses:

D. G. STUART,
JOS. N. YOUNG.

J. FORREST.
Self-Lighting Lamps for Light-Houses.
No. 204,806. Patented June 11, 1878.

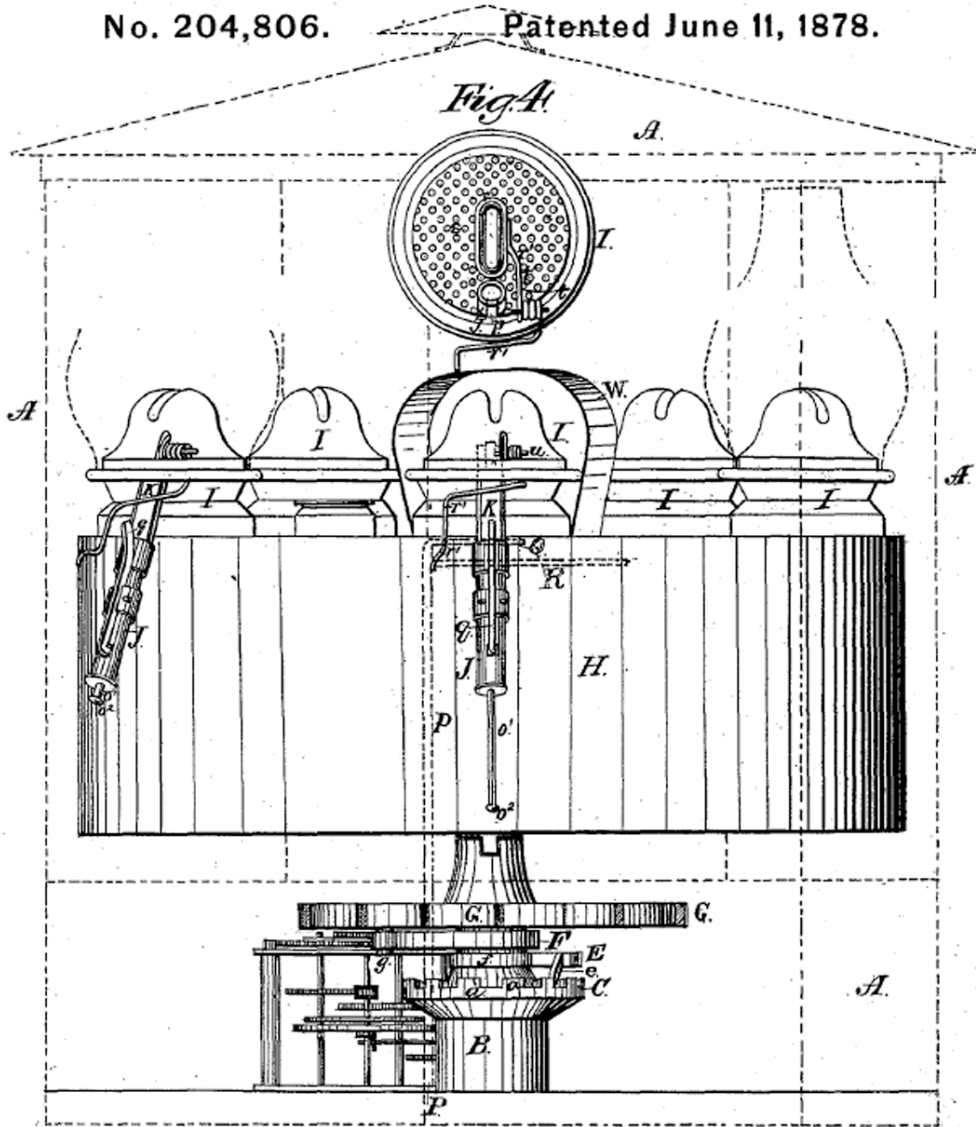

Fig. 1.

Attest:
G. D. Brock
D. Y. Stuart

Inventor:
Joseph Forrest
per
D. H. Henny
Attorney.

J. FORREST.
Self-Lighting Lamps for Light-Houses.

No. 204,806.

Patented June 11, 1878.

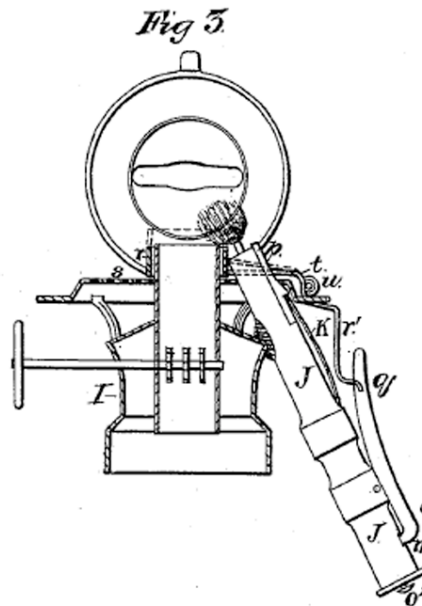
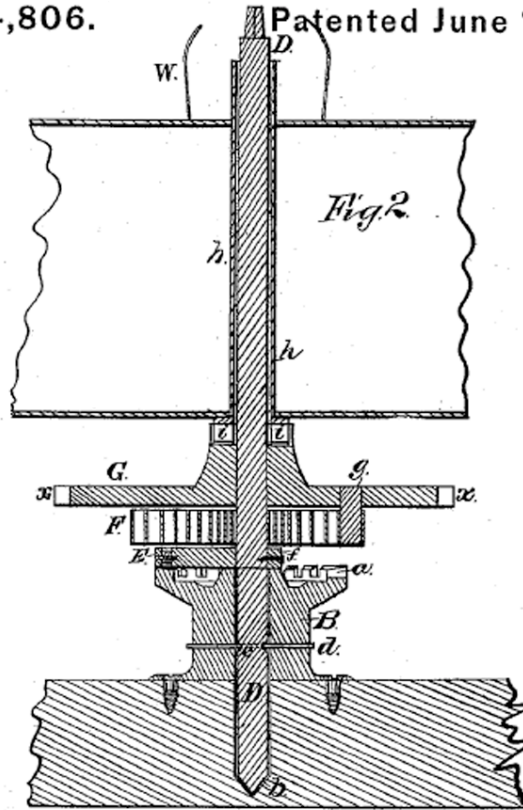

Attest:
F. S. Brock
D. G. Stuart

Inventor:
Joseph Forrest
 per
S. Hannay
 Attorney.

J. FORREST.
Self-Lighting Lamps for Light-Houses.
No. 204,806. Patented June 11, 1878

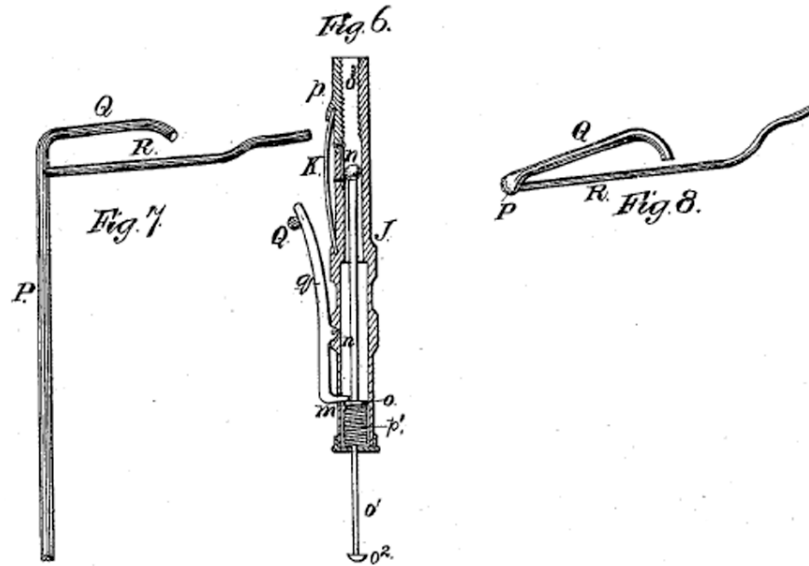
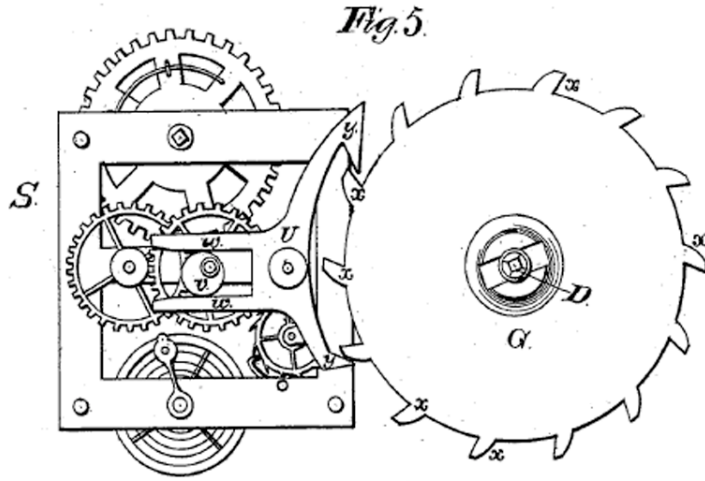

Attest:
J. B. Brock.
D. G. Stuart

Inventor:
Joseph Forrest
per *P. H. May*
Attorney.

Joseph Forrest's Design was never used in America. However, a very similar design was used in the lighthouses of Canada.



(Photo Courtesy Smithsonian Institution, National Museum of American History, Home and Community Life)
RWS2012-04607 Patent 204806 Lighthouse Lamp Self Lighting.